



PNEUMATIC TIRE ROLLERS



THE PRESSURE IS ON

WITH NEW PNEUMATIC ROLLERS

PRODUCTIVE IN ANY APPLICATION

Your crew needs a roller that can adjust on the fly to changing conditions, and even applications. The Cat® Pneumatic Tire Rollers do exactly that. The rollers easily take on (or shed) ballast to deliver the varied contact pressures you need.

The result is consistently achieving density targets, whether compacting granular materials or asphalt. The success continues through final compaction, where precise contact pressures provide the proper finishing touches.

COMPACTION PERFORMANCE

- Compaction width of 2 090 mm (82") for CW34, 1 740 mm (68") for CW14 and PS150C
- Versatile operating weights
- Ballast systems for easy weight adjustment
- Optional Air-on-the-Run tool on CW34 automatically adjusts tire pressure

VISIBILITY, CONTROL AND COMFORT

- Easy-to-reach, responsive controls
- Intuitive console design
- Sliding and rotating operator station on CW34
- Optional rotating operator station on PS150C / CW14

UNMATCHED UPTIME AND VALUE

- Powered by durable, reliable Cat engines
- Standard 500-hour engine oil service interval maximizes uptime and minimizes lifetime operating costs
- Large cooling system keeps components cool, even in high ambient temperatures, for long life
- Advanced water spray and emulsion systems prevent asphalt pickup and costly on-site adjustments



1. Flexible Ballast Options
2. Modular Ballast (CW34)
3. Cat Compaction Control (Option for CW34)
4. Roomy Operating Environment
5. Air-on-the-Run (Option for CW34)
6. Edge Cutter / Compactor (Option for CW34)



APPLICATIONS

- Highways
- City streets
- County roads
- Lane additions
- Overlays
- Industrial sites
- Parking lots
- Airport runways
- Production-sized jobs
- Base materials
- Binder course
- Wear course
- Soil applications
- Lime or cement compaction

COMPACTION PERFORMANCE

MANY OPTIONS AVAILABLE

EASY ADJUSTMENTS MAKE THE DIFFERENCE

Cat Pneumatic Tire Rollers are able to work on granular material and asphalt, enabling you to compact everything from a sub-base to the surface lift of asphalt with a single machine. When extra pressure is (or isn't) needed on a specific portion of a job, you can easily adjust the ballast—or with the CW34 take advantage of the Air-on-the-Run option—and fine-tune the roller for your working conditions.

OSCILLATING TIRES

- Oscillating front and rear tires deliver vertical and horizontal forces that reduce air voids, ensuring surface uniformity
- Vertical suspension improves results on uneven surfaces by uncovering voids and enabling consistent, uniform compaction

FLEXIBLE BALLAST

- Ballast options include sand, steel and water
- Modular and non-modular steel ballast option on CW34
 - 6.5 metric ton (7.1 U.S. ton) modular steel
 - 6.1 metric ton (6.7 U.S. ton) non-modular steel
 - 3 cu m (793 gal) water-tight chamber
- Baffled compartments prevent surge, balance weight
- Large doors provide easy component access
- Large drain port

The CW34 features modular steel ballast that are easy to add or remove.





PICK-UP PREVENTION

LEAVE THE ASPHALT WHERE IT BELONGS

A SMOOTH FINAL STEP

A paving job can go from success to failure in a hurry if the tires start picking up asphalt. That's why Caterpillar placed special emphasis on the design and functionality of water spray and emulsion systems. If each tire isn't properly covered, all your previous hard work can vanish.

KEY FEATURES

- Dedicated spray nozzles for each tire
- Standard pressurized system on the CW34 includes water pump, triple filtration, and adjustable intermittent operation
- Standard gravity fed system on the CW14 and PS150C
- Optional emulsion spray system with dedicated tank, lines and spray bars enables utilization of release agents on the wheels for additional protection against asphalt adhesion

OTHER ASPHALT PICKUP PREVENTIONS

- *Tires equipped with self-adjusting scrapers*
- *Optional cocoa mats improve water coverage*
- *Heat-retention covers trap heat*





ENGINES AND POWERTRAINS

POWER AND PRECISION

LOWER FUEL CONSUMPTION, SOUND LEVELS

Your operators need power to get the job done, hour after hour, and the Cat engines on Pneumatic Tire Rollers deliver. The engines do more than propel the rollers. They also help reduce fuel consumption. You can have your power—and your fuel savings, too.

The CW34 operates efficiently at temperatures up to 49° C (120° F) with maximum engine load, due to the high-volume cooling system and large fan.

CW34 ENGINE

- Standard ECO-mode provides fuel efficiency and reduces sound levels
- Automatic speed control enables operator to tune the system for maximum speed within low, intermediate and high ranges
 - Operating in intermediate and high, the system shifts smoothly through the speed ranges and has a maximum speed of 19 km/hr (12 mph) for quick movement around and between jobsites
 - System has the ability to coast, leading to less fuel consumption and lower sound levels for a more comfortable environment

U.S. EPA TIER 4 INTERIM/EU STAGE IIIB EMISSIONS STANDARDS

- Reduces oxides of nitrogen by 50 percent from Tier 3/Stage IIIA levels
- Reduces particulate matter by 90 percent from Tier 3/Stage IIIA levels
- Ultra Low Sulfur Diesel (ULSD) fuel is required
 - Sulfur content is reduced to 15 ppm (mg/kg)
 - Bio-diesel up to B20 can be utilized when blended with ULSD, refer to the Cat Fluids Guide for more information
- Engine oil must meet Caterpillar ECF-3, API CJ-4/ACEA E9 specifications
 - Reduced sulfated ash, phosphorus, and sulfur

EMISSIONS REDUCTION TECHNOLOGY

- The engines that meet U.S. EPA Tier 4 Interim and EU Stage IIIB emission standards are equipped with a Diesel Particulate Filter (DPF) that traps soot from the exhaust stream. The soot is removed through a process called regeneration, while the ash remains in the filter.

ACTIVE AND PASSIVE REGENERATION

- Passive regeneration occurs during normal load conditions; engine exhaust temperatures are sufficient to remove the soot
- Active regeneration occurs when the diesel particulate filter (DPF) is at an elevated soot level; an integrated regeneration system introduces a small amount of fuel to remove the soot
- Regeneration occurs during normal idle periods or during operation
- Both passive and active regeneration are self-activating and do not require operator initiation

1. CW14 Regeneration Enable/Disable Switch
2. CW14 Regeneration Indicator

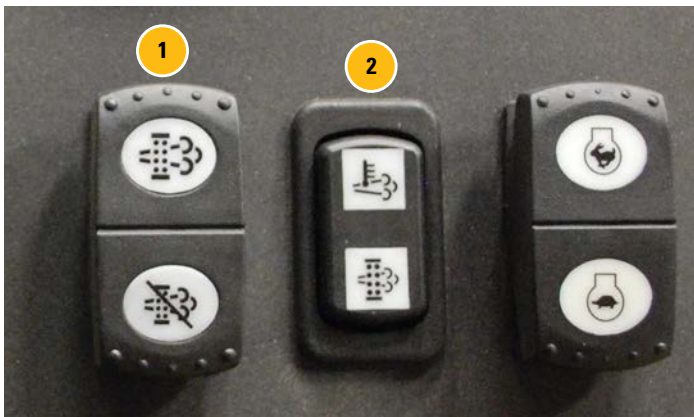

POWERFUL ENGINES



CW34 ENGINE OPTIONS

The C4.4 engine is available in two models in order to meet emission standards for higher regulated and lesser regulated markets.

- Model 1 utilizes passive regeneration and meets U.S. EPA Tier 4 Interim/EU Stage IIIB emission standards for higher regulated markets
 - Power for Model 1 is 98 kW, 133.2 hp (m), 131 hp (l)
- Model 2 meets emission standards equivalent to U.S. EPA Tier 3 and EU Stage IIIA for lesser regulated markets
 - Power for Model 2 is 96.5 kW, 131.2 hp (m), 129 hp (l)

CW14 ENGINE

- Features Cat C3.4B engine that utilizes passive and active regeneration and meets U.S. EPA Tier 4 Interim and EU Stage IIIB emission standards
- Power is 75 kW, 102 hp (m), 100 hp (l)
- DPF filter has a required minimum service interval of 3000 hours.

* Note: The CW14 is equipped with an enable/disable switch that allows the operator to force a manual regeneration when the DPF filter is at an elevated level. Manual regeneration is normally only required when automatic regeneration has been repeatedly disabled before completing its cycle.

PS150C ENGINE

- Features four cylinder 3054C turbocharged diesel engine that meets U.S. EPA Tier 2 standards
- Power is 75 kW, 102 hp (m), 100 hp (l)

CW34 COMFORT AND CONTROL

CAT® COMPACTION CONTROL

THE CONFIDENCE YOU NEED

Your operators need answers while they're rolling. What is the temperature? Where have I been, and where do I go next? The optional Cat Compaction Control helps provide those answers. The result: operators who can quickly adjust to changing conditions—and at the end of the day are confident the job was done right.

KEY BENEFITS

- Maximize density
- High performance and efficiency; no unnecessary passes
- Hit mats at the optimal temperatures
- Ensure complete coverage
- Simplify night-time operation

CAT COMPACTION CONTROL FEATURES

- Easy-to-use interface
- Pass-count mapping keeps operator informed regarding the number of completed passes
- Operator informed of mat temperatures through infrared sensors, located on both the front and rear for accuracy
- Sensors combine with mapping to inform operator when optimal conditions exist, and where compaction has occurred
- Temperature mapping records data for future analysis and quality control documentation



Boost operator productivity by preventing unnecessary passes.



CW34 CAT



Easy-to-use interfaces keep operators informed.

IMPROVED COMFORT

ENHANCED VISIBILITY, SIMPLIFIED OPERATION, REDUCED SOUND

- Full floor-to-ceiling glass on cab-equipped machines enables good sight lines to tire edges on both sides of the machine
- Operator can easily view 1 m x 1 m (3.2' x 3.2') in front of machine
- Optional sun canopy can be added to the ROPS for increased protection in adverse conditions
- Sliding and pivoting operator station rotates 90° to either side for ultimate comfort and control
- New console design
- LCD display and push button machine controls simplify operation for an all-around comfortable operating environment
- Exclusive automotive-type powertrain with continuously variable engine speed provides smooth shifting through three speed ranges
- Engine's ability to "coast" lowers sound levels

OTHER HIGHLIGHTS

- ECO-mode saves fuel, reduces sound levels
- Eight 13/80 R20 rubber tires provide overall compaction width of 2 090 mm (82") with 42 mm (1.5") overlap
- Air-on-the-Run option enables operator to quickly adjust tire pressures to increase or decrease static loads for optimal surface quality
- Machine controller compatible with Cat Electronic Technician



CW14 AND PS150C KEY FEATURES AND BENEFITS

SIMPLE AND RELIABLE

EXPAND YOUR SOLUTIONS

The Cat CW14 and PS150C provide a standard nine-wheel configuration that helps your crew reach compaction goals on asphalt or granular materials. You can make the rollers even more versatile with an option to expand to 11 tires.

HIGHLIGHTS

- Cat 3.4B engine meets U.S. EPA Tier 4 emission standards
- Operating weight of 4 885 kg to 17 232 kg (10,770 lb to 38,000 lb) for excellent versatility and performance
- Efficient engine and durable rubber tires minimize life-time operating costs and maximize profit
- Delivers smooth, reliable performance on grades and soft base materials
- Option to utilize nine or 11 tires

EXCEPTIONAL VISIBILITY AND CONTROL

- Rotating operator's station
- Adjustable seat
- Simple controls

SMOOTH OPERATING POWERTRAIN

- Hydrostatic propel control and smooth braking system
- Two-speed hydrostatic propel system delivers excellent gradeability with speeds up to 18 km/hr (11 mph)

VERSATILE COMPACTION PERFORMANCE

- Flexible ballast system and oscillating front and rear tires
- Ballast options include sand, steel and water, making for quick, easy jobsite matches

SIMPLE SERVICE

- Easy-viewing sight gauges
- Convenient filter access
- Color-coded electrical wiring and connections
- Ground-level service access



A durable engine and long-lasting tires provide value and lower operating costs over the life of the rollers.



1. 9- or 11-tire option
2. Adjustable Seat
3. Contoured Water Tank for Good Sight Lines
4. Gravity Tire Spray System
5. Flexible Ballast Options
6. Cat C3.4B Engine
7. Rotating Operator Station (option)
8. Heat Retention Covers



CW34 SPECIFICATIONS

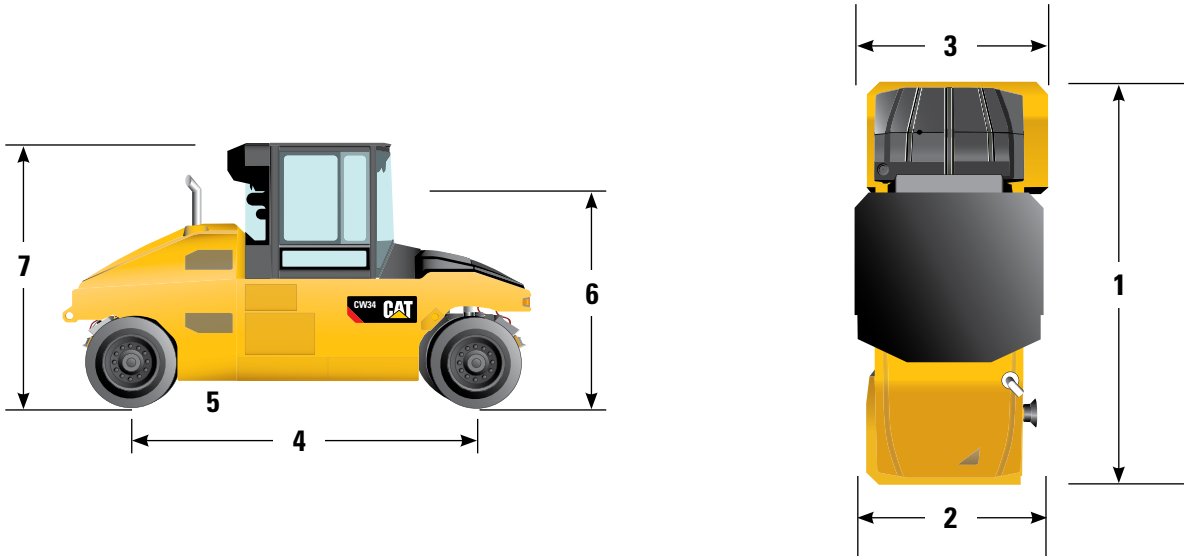

Engine – Powertrain

Engine Model: Cat C4.4 w/ACERT Technology

Number of Cylinders	4
Rated Speed	2 200 rpm
Bore	105 mm (4.13")
Stroke	127 mm (5")

Gross Power (2 Engine Options):

Tier 4 Interim, Stage IIIB	98 kW, 133.2 hp (m), 131 hp (l)
Tier 3, Stage IIIA Equivalent	96.5 kW, 131.2 hp (m), 129 hp (l)

Speed Ranges:

Low	0 - 6 km/hr (0 - 4 mph)
Medium	0 - 12 km/hr (0 - 7 mph)
High	0 - 19 km/hr (0 - 12 mph)

Dimensions

1 Overall length	5 350 mm (17' 6")
2 Compaction width	2 090 mm (82")
Tire overlap	42 mm (1.5")
3 Frame width	2 160 mm (7' 1")
4 Wheelbase	3 900 mm (12' 9")
5 Ground clearance	
- without ballast	309 mm (12")
- with ballast	260 mm (10")
6 Height (steering wheel)	2 450 mm (96")
7 Height (cab, ROPS)	3 000 mm (9' 10")

Service Refill Capacities

Fuel Tank	270 L (71 gal)
Cooling System	27 L (7 gal)
Engine Oil	9 L (2.4 gal)
Hydraulic Tank	32 L (8.5 gal)
Water Tank	380 L (100 gal)
Emulsion Tank	40 L (10.5 gal)

CW34 SPECIFICATIONS

Weights

Operating Weights	Load per Wheel		
Base machine	10 000 kg	(22,050 lb)	1.25 mt
Water	13 000 kg	(28,660 lb)	1.62 mt
Wet sand	16 000 kg	(35,275 lb)	2.00 mt
Modular steel	16 450 kg	(36,265 lb)	2.05 mt
Modular steel w/water	19 450 kg	(42,880 lb)	2.43 mt
Modular steel w/wet sand	22 450 kg	(49,495 lb)	2.80 mt
Modular and non-modular steel	22 550 kg	(49,715 lb)	2.82 mt
Modular and non-modular steel w/water	24 700 kg	(54,450 lb)	3.08 mt
Modular and non-modular steel w/wet sand	27 000 kg	(59,525 lb)	3.38 mt

Ground Contact Pressures

		TIRE PRESSURE							
		300 kPa 44 psi	400 kPa 58 psi	500 kPa 73 psi	600 kPa 87 psi	700 kPa 102 psi	800 kPa 116 psi	850 kPa 123 psi	900 kPa 131 psi
AVERAGE WHEEL LOAD	1500 kg (3,307 lb)	242 kPa 35 psi	309 kPa 45 psi	406 kPa 59 psi	612 kPa 89 psi	680 kPa 99 psi	1038 kPa 151 psi	1265 kPa 184 psi	1587 kPa 230 psi
	2000 kg (4,410 lb)	260 kPa 38 psi	299 kPa 43 psi	357 kPa 52 psi	462 kPa 67 psi	498 kPa 72 psi	628 kPa 91 psi	691 kPa 100 psi	764 kPa 111 psi
	2500 kg (5,512 lb)	308 kPa 45 psi	322 kPa 47 psi	360 kPa 52 psi	429 kPa 62 psi	458 kPa 66 psi	539 kPa 78 psi	577 kPa 84 psi	618 kPa 90 psi
	3000 kg (6,614 lb)	397 kPa 58 psi	369 kPa 54 psi	386 kPa 56 psi	433 kPa 63 psi	457 kPa 66 psi	516 kPa 75 psi	543 kPa 79 psi	573 kPa 83 psi
	3375 kg (7,441 lb)	518 kPa 75 psi	423 kPa 61 psi	418 kPa 61 psi	448 kPa 65 psi	469 kPa 68 psi	517 kPa 75 psi	539 kPa 78 psi	564 kPa 82 psi

STANDARD EQUIPMENT

- 24-Volt Electrical System
- 3 m³ (793 gal) Water-Tight Ballast Chamber
- 13/80-R20 Tires
- 100-Amp Alternator
- ECO-Mode
- Front Wheel Suspension
- Halogen Working Lights
- LCD Operating Display
- Product Link Ready
- Pressurized Water Spray w/Triple Filtration
- Roading Lights
- Sliding Operator Station w/180° Rotation
- Three-Speed Propel System
- Vinyl Seat with 76 mm (3") Wide Belt
- Wheel Oscillation

CW14 AND PS150C SPECIFICATIONS

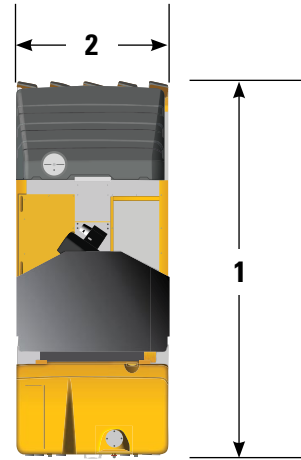
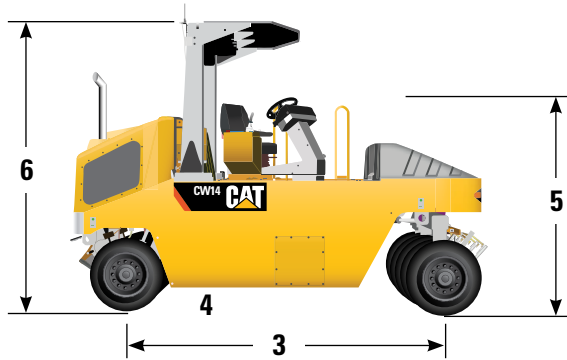

Engine – Powertrain for CW14

Engine Model: Cat C3.4B

Number of Cylinders	4
Rated Speed	2 200 rpm
Bore	99 mm (3.89")
Stroke	110 mm (4.33")

Gross Power:

Tier 4 Interim/Stage IIIB	75 kW, 100.6 (l) hp, 102 (m) hp
---------------------------	---------------------------------

Speed Ranges:

Low	0 - 6 km/hr (4 mph)
High	0 - 18 km/hr (12 mph)

Engine – Powertrain for PS150C

Engine Model: Cat 3054C Turbocharged Diesel

Number of Cylinders	4
Rated Speed	2 200 rpm
Bore	105 mm (4.13")
Stroke	127 mm (5")

Gross Power:

Tier 2	75 kW (100 hp)
--------	----------------

Speed Ranges:

Low	0 - 6 km/hr (4 mph)
High	0 - 18 km/hr (11 mph)

Dimensions

1 Overall length	4 290 mm (14' 1")
2 Compaction width	1 740 mm (68")
Tire overlap	13 mm (0.5")
3 Wheelbase	3 340 mm (10' 11")
4 Ground clearance	267 mm (10.5")
5 Height (steering wheel)	2 320 mm (91")
6 Height (ROPS)	3 000 mm (9' 10")

Service Refill Capacities

Fuel Tank	173 L	(45.6 gal)
Cooling System	32 L	(8.5 gal)
Engine Oil w/filter	9 L	(2.4 gal)
Hydraulic Tank	20.5 L	(5.4 gal)
Water Tank	394 L	(104 gal)

STANDARD EQUIPMENT

- 12-Volt Electrical System w/120 amp Alternator (CW14)
- 24-Volt Electrical System w/55 amp Alternator (PS150C)
- Water-Tight Ballast Chamber
- Halogen Working Lights
- Product Link Ready
- Gravity Water System
- Rooding Lights
- Wheel Oscillation
- Nine, 8-50/90 x 15 6-ply tires
- Extended Life Coolant
- Cocoa Mats

CW14 AND PS150C SPECIFICATIONS

Weights

Operating Weights

CW14 and PS150C	Load per Wheel		
Base machine	4 885 kg	(10,770 lb)	0.54 mt
Water	8 710 kg	(19,202 lb)	0.96 mt
Wet sand	12 940 kg	(28,528 lb)	1.44 mt
CW14 and PS150C w/11 Wheel Option			
Base machine	4 955 kg	(10,924 lb)	0.45 mt
Water	8 780 kg	(19,357 lb)	0.80 mt
Wet sand	13 010 kg	(28,682 lb)	1.19 mt
CW14 and PS150C w/Heavy Weight Option			
Base machine	4 955 kg	(10,924 lb)	0.55 mt
Water	8 780 kg	(19,357 lb)	0.97 mt
Wet sand	13 010 kg	(28,682 lb)	1.44 mt
Steel and wet sand	17 273 kg	(38,000 lb)	1.92 mt

Ground Contact Pressures

TIRE PLY	6-Ply 8.5/90x15 Smooth Tires		12-Ply 7.5x15 Smooth Tires							14-Ply 7.5x15 Smooth Tires								
Tire Pressure (kPa/psi)	275/40	344/50	344/50	413/60	482/70	550/80	619/90	688/100	757/110	344/50	413/60	482/70	550/80	619/90	688/100	757/110	825/120	862/125
WHEEL LOAD 545 kg/1,200 lb																		
GCP (kPa/psi)	162/24	183/272	236/34	266/39	284/41	306/44	317/46	317/46	344/50	243/35	266/39	284/41	295/43	317/46	330/48	344/50	359/52	367/53
CA (cm²/in²)	329/51	291/45	226/35	200/31	187/29	174/27	168/26	168/25	155/24	220/34	200/31	187/29	181/28	168/26	162/25	155/24	149/23	145/22
970 kg/2,145 lb																		
GCP (kPa/psi)	197/29	214/31	250/36	284/41	314/46	343/50	369/54	378/55	410/60	259/38	295/43	321/47	343/50	369/54	388/56	420/60	421/61	427/62
CA (cm²/in²)	485/75	446/69	381/59	336/52	304/47	278/43	258/40	252/39	233/36	368/57	323/50	297/46	278/43	258/40	245/382	233/36	226/35	223/34
1 440 kg/3,180 lb																		
GCP (kPa/psi)	235/34	254/37	280/41	304/44	331/48	358/52	390/57	405/59	607/88	273/40	312/45	336/49	364/53	390/57	413/60	437/64	465/88	475/69
CA (cm²/in²)	601/93	556/86	504/78	465/72	426/66	394/61	362/56	349/54	233/36	517/80	452/70	420/65	388/60	362/56	342/53	323/50	304/47	297/46
1 920 kg/4,220 lb																		
GCP (kPa/psi)	–	–	296/43	319/47	346/50	368/53	387/56	403/59	440/64	309/45	319/47	341/49	354/51	372/54	387/56	403/59	414/60	417/61
CA (cm²/in²)	–	–	601/93	559/86	516/80	485/75	461/71	442/68	405/63	577/89	559/86	522/81	504/78	479/74	461/71	442/68	429/67	427/66

Having a goal like being the paving industry sales leader is no small challenge, even for the worldwide leader in the manufacture of equipment for the construction industry.

But ever since we sold our first paving equipment in 1986, we have continued to grow. Over the years, our machines have been recognized as dependable and rugged, easy to use and highly productive.

We have introduced innovations that have changed the way the world builds roads, features that our competitors now offer on their machines.

And with each new generation of machines we introduce, more and more customers around the world make the decision to switch to Cat.

For more complete information on Cat products, dealer services, and industry solutions, visit us on the web at www.cat.com.

PAVING ALL DAY. EVERY DAY.



QEDQ1627-04 (10/12)

© 2012 Caterpillar
All Rights Reserved

Materials and specifications are subject to change without notice.

Featured machines in photography may include additional equipment for special applications.

CAT, CATERPILLAR, their respective logos, "Caterpillar Yellow" and the POWER EDGE trade dress, as well as corporate and product identity used herein, are trademarks of Caterpillar and may not be used without permission.

