



WEIGHT CHANGES

Tires or attachments	Operating weight		Tipping load straight		Tipping load full turn		Width over tires		Ground clearance		Change in vertical dimensions	
	kg	lb	kg	lb	kg	lb	mm	ft in	mm	ft in	mm	ft in
23.5-25-20PR(L-3)	-305	-672	-240	-529	-210	-463	2920	9'7"	460	1'6"	-65	-3"
23.5-25-20PR(L-2)	-615	-1,355	-480	-1,058	-420	-926	2920	9'7"	460	1'6"	-65	-3"
26.5-25-16PR(L-3)	0	0	0	0	0	0	3010	9'11"	525	1'9"	0	0
26.5-25-20PR(L-4)	+425	+937	+330	+728	+290	+639	3010	9'11"	525	1'9"	0	0
Install additional counterweight	+400	+880	+1070	+2,358	+930	+2,050						



STANDARD EQUIPMENT

- 2-spool valve for boom and bucket controls
- Alternator, 50 A
- Auto shift transmission with mode select system
- Back-up alarm
- Back-up lamp
- Batteries, 136 Ah/12 V x 2
- Counterweight
- Directional signal
- Engine, Komatsu SAA6D125E-5 diesel
- Engine shut-off system, electric
- Hard water area arrangement (corrosion resister)
- Hydraulic-driven fan with reverse rotation
- Lift cylinders and bucket cylinder
- Main monitor panel with EMMS (Equipment Management Monitoring System)
- PPC fingertip control, two levers
- Radiator mask, lattice type
- Rearview mirror for cab
- Rear window washer and wiper
- ROPS/FOPS cab
- Seat belt
- Seat, suspension type with reclining
- Service brakes, wet disc type
- Starting motor, 7.5 kW/24 V
- Steering wheel, tiltable, telescopic
- Sun visor
- Tires (26.5-25-16PR tubeless) and rims
- Transmission, 4 forward and 4 reverse



OPTIONAL EQUIPMENT

- 12V converter
- 3-spool valve
- Additional counterweight
- Air conditioner
- AM/FM radio
- AM/FM stereo radio cassette
- Batteries, 140 Ah/12V x 2
- Bucket teeth (bolt-on type)
- Bucket teeth (tip type)
- Cutting edge (bolt-on type)
- ECSS (Electronically Controlled Suspension System)
- Emergency steering (SAE)
- Engine pre-cleaner with extension
- Fire extinguisher
- Floor mat
- Front fender
- High lift boom
- Joystick steering
- Load meter, new type
- Lock-up clutch torque converter
- Ordinary spare parts
- Power train guard
- Seat, air suspension with automatic weight adjustment
- Segment edges
- Tool kit
- Vandalism protection kit
- Limited slip differential (F&R)

www.Komatsu.com

Printed in Japan 200806 IP.SIN (10)

KOMATSU®

CEN00133-03

Materials and specifications are subject to change without notice
KOMATSU is a trademark of Komatsu Ltd. Japan

HORSEPOWER

Gross: 204 kW 273 HP @ 2000 rpm

Net: 203 kW 272 HP @ 2000 rpm

BUCKET CAPACITY

3.6–5.2 m³ 4.7–6.8 yd³

KOMATSU®

WA470-6

ecot3

WA 470

WHEEL LOADER



Photo may include optional equipment.

SPECIFICATIONS



ENGINE

ModelKomatsu SAA6D125E-5
 TypeWater-cooled, 4-cycle
 AspirationTurbocharged, aftercooled, cooled EGR
 Number of cylinders6
 Bore x stroke125 mm x 150 mm 4.9" x 5.9"
 Piston displacement11.04 ltr 674 in³
 Governorall-speed, electronic
 Horsepower
 SAE J1995Gross **204 kW** 273 HP
 ISO 9249/SAE J1349*Net **203 kW** 272 HP
 Rated rpm2000 rpm
 Fan drive method for radiator coolingHydraulic
 Fuel systemDirect injection
 Lubrication system:
 MethodGear pump, force-lubrication
 FilterFull-flow type
 Air cleanerDry type with double elements and dust evacuator, plus dust indicator

*Net horsepower at the maximum speed of radiator cooling fan is 191 kW 256 HP.



TRANSMISSION

Torque converter:
 Type3-element, single-stage, single-phase
 Transmission:
 TypeFull-powershift, countershaft type
 Travel speed: **km/h** mph
 Measured with 23.5-25 tires

	1st	2nd	3rd	4th
Forward	7.0 4.3	12.2 7.6	21.3 13.2	33.7 20.9
Reverse	7.3 4.5	12.6 7.8	21.9 13.6	34.7 21.6

Measured with 26.5-25 tires

	1st	2nd	3rd	4th
Forward	7.6 4.7	13.1 8.1	22.9 14.2	36.2 22.5
Reverse	7.9 4.9	13.5 8.4	23.6 14.7	37.3 23.2



AXLES AND FINAL DRIVES

Drive systemFour-wheel drive
 FrontFixed, semi-floating
 RearCenter-pin support, semi-floating,
 26° total oscillation
 Reduction gearSpiral bevel gear
 Differential gearConventional type
 Final reduction gearPlanetary gear, single reduction



BRAKES

Service brakesHydraulically actuated,
 wet disc brakes actuate on four wheels
 Parking brakeWet disc brake
 Emergency brakeParking brake is commonly used



STEERING SYSTEM

TypeArticulated type, full-hydraulic power steering
 Steering angle35° each direction (40° end stop)
 Minimum turning radius at the center of outside tire6630 mm 21'9"



HYDRAULIC SYSTEM

Steering system:
 Hydraulic pumpPiston pump
 Capacity195 ltr/min 51.5 U.S. gal/min at rated rpm
 Relief valve setting24.5 MPa 250 kgf/cm² 3,555 psi
 Hydraulic cylinders:
 TypeDouble-acting, piston type
 Number of cylinders2
 Bore x stroke90 mm x 441 mm 3.5" x 17.3"

Loader control:
 Hydraulic pumpPiston pump
 Capacity260 ltr/min 68.7 U.S. gal/min at rated rpm
 Relief valve setting34.3 MPa 350 kgf/cm² 4,980 psi
 Hydraulic cylinders:
 TypeDouble-acting, piston type
 Number of cylinders—bore x stroke:
 Boom cylinder2- 140 mm x 764 mm 5.5" x 30.0"
 Bucket cylinder1- 160 mm x 575 mm 6.3" x 22.6"

Control valve2-spool type
 Control positions:
 BoomRaise, hold, lower, and float
 BucketTilt-back, hold, and dump
 Hydraulic cycle time (rated load in bucket)
 Raise5.4 sec
 Dump1.6 sec
 Lower (Empty)3.7 sec



SERVICE REFILL CAPACITIES

Cooling system61 ltr 16.1 U.S. gal
 Fuel tank413 ltr 109.1 U.S. gal
 Engine38 ltr 10.0 U.S. gal
 Hydraulic system173 ltr 45.7 U.S. gal
 Axle front60 ltr 15.9 U.S. gal
 rear56 ltr 14.8 U.S. gal
 Torque converter and transmission65 ltr 17.2 U.S. gal



BUCKET SELECTION GUIDE

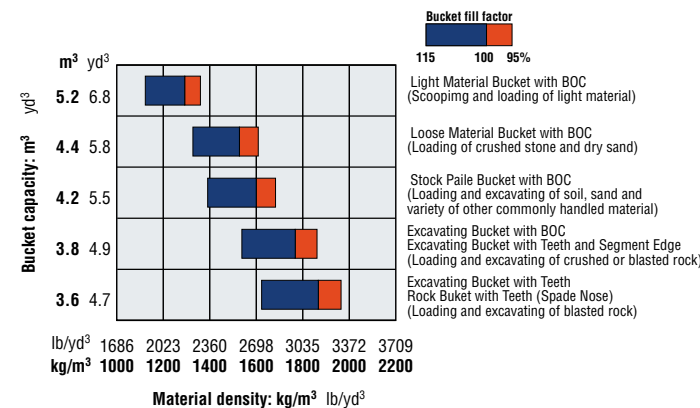

DIMENSIONS

Measured with 26.5-25-16PR (L3) tires

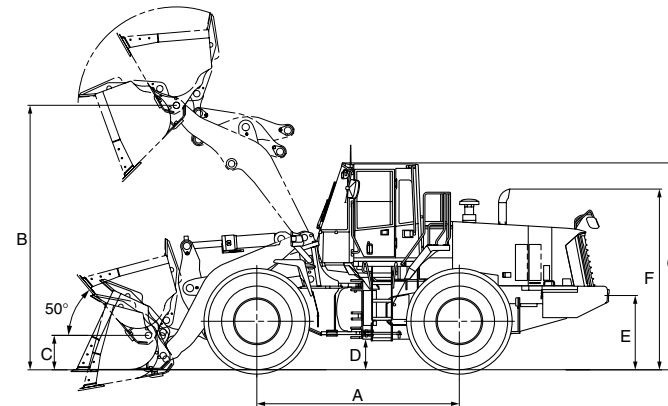

Tread	2300 mm	7'7"
Width over tires	3010 mm	9'11"
A Wheelbase	3450 mm	11'4"
B Hinge pin height, max. height	4360 mm	14'4"
C Hinge pin height, carry position	585 mm	1'11"
D Ground clearance	525 mm	1'9"
E Hitch height	1240 mm	4'1"
F Overall height, top of the stack	3080 mm	10'1"
G Overall height, ROPS cab	3500 mm	11'6"

	General Purpose Buckets					Rock Bucket (Spade nose)	Loose Material Bucket	Light Material Bucket
	Stockpile		Excavating					
	Bolt-on Cutting edges	Teeth	Bolt-on Cutting edges	Teeth and Segments	Teeth			
Bucket capacity: heaped	4.2 m ³ 5.5 yd ³	3.9 m ³ 5.1 yd ³	3.8 m ³ 5.0 yd ³	3.8 m ³ 5.0 yd ³	3.6 m ³ 4.7 yd ³	3.6 m ³ 4.7 yd ³	4.4 m ³ 5.8 yd ³	5.2 m ³ 6.8 yd ³
struck	3.5 m ³ 4.6 yd ³	3.3 m ³ 4.3 yd ³	3.2 m ³ 4.2 yd ³	3.2 m ³ 4.2 yd ³	3.1 m ³ 4.1 yd ³	3.1 m ³ 4.1 yd ³	3.9 m ³ 5.1 yd ³	4.5 m ³ 5.9 yd ³
Bucket width	3170 mm 10'5"	3190 mm 10'6"	3170 mm 10'5"	3190 mm 10'6"	3190 mm 10'6"	3170 mm 10'5"	3170 mm 10'5"	3170 mm 10'5"
Bucket weight	2050 kg 4,519 lb	1970 kg 4,343 lb	2150 kg 4,740 lb	2200 kg 4,850 lb	2070 kg 4,564 lb	2165 kg 4,773 lb	2110 kg 4,652 lb	2185 kg 4,817 lb
Dumping clearance, max. height and 45° dump angle*	3185 mm 10'5"	3060 mm 10'0"	3235 mm 10'7"	3110 mm 10'2"	3110 mm 10'2"	2975 mm 9'9"	3055 mm 10'0"	3035 mm 9'11"
Reach at max. height and 45° dump angle*	1235 mm 4'1"	1335 mm 4'5"	1185 mm 3'11"	1285 mm 4'3"	1285 mm 4'3"	1435 mm 4'8"	1365 mm 4'6"	1385 mm 4'7"
Reach at 2130 mm (7') clearance and 45° dump angle	1935 mm 6'4"	1975 mm 6'6"	1905 mm 6'3"	1950 mm 6'5"	1950 mm 6'5"	2035 mm 6'8"	2010 mm 6'7"	2020 mm 6'8"
Reach with arm horizontal and bucket level	2755 mm 9'0"	2910 mm 9'7"	2685 mm 8'10"	2840 mm 9'4"	2840 mm 9'4"	3040 mm 10'0"	2940 mm 9'8"	2965 mm 9'9"
Operating height (fully raised)	5960 mm 19'7"	5960 mm 19'7"	5875 mm 19'3"	5875 mm 19'3"	5875 mm 19'3"	5875 mm 19'3"	5960 mm 19'7"	6185 mm 20'4"
Overall length	8825 mm 28'11"	8980 mm 29'6"	8755 mm 28'9"	8910 mm 29'3"	8910 mm 29'3"	9210 mm 29'11"	9010 mm 29'7"	9035 mm 29'8"
Loader clearance circle (35°) (bucket at carry, outside corner of bucket)	15280 mm 50'2"	15380 mm 50'6"	15240 mm 50'0"	15340 mm 50'4"	15340 mm 50'4"	15280 mm 50'2"	15370 mm 50'5"	15380 mm 50'6"
Digging depth: 0°	80 mm 3.1"	100 mm 3.9"	80 mm 3.1"	100 mm 3.9"	100 mm 3.9"	85 mm 3.3"	80 mm 3.1"	80 mm 3.1"
10°	315 mm 1'0"	360 mm 1'2"	305 mm 1'0"	350 mm 1'2"	350 mm 1'2"	370 mm 1'3"	345 mm 1'2"	350 mm 1'2"
Static tipping load: straight	18295 kg 40,330 lb	18370 kg 40,500 lb	18205 kg 40,130 lb	18160 kg 40,040 lb	18275 kg 40,290 lb	18190 kg 40,100 lb	18240 kg 40,210 lb	18175 kg 40,070 lb
40° full turn	15720 kg 34,660 lb	15795 kg 34,820 lb	15630 kg 34,460 lb	15585 kg 34,360 lb	15705 kg 34,620 lb	15615 kg 34,420 lb	15665 kg 34,530 lb	15600 kg 34,390 lb
Breakout force	192 kN 19600 kgf 43,160 lb	207 kN 21120 kgf 46,560 lb	203 kN 20710 kgf 45,660 lb	209 kN 21330 kgf 47,020 lb	220 kN 22450 kgf 49,490 lb	190 kN 19390 kgf 42,750 lb	168 kN 17140 kgf 37,790 lb	165 kN 16840 kgf 37,130 lb
Operating weight	22960 kg 50,620 lb	22880 kg 50,440 lb	23060 kg 50,840 lb	23110 kg 50,950 lb	22980 kg 50,660 lb	23075 kg 50,870 lb	23020 kg 50,750 lb	23095 kg 50,910 lb

* At the end of tooth or B.O.C.

All dimensions, weights, and performance values based on SAE J732c and J742b standards.

Static tipping load and operating weight shown include lubricant, coolant, full fuel tank, ROPS cab, and operator. Machine stability and operating weight affected by counterweight, tire size, and other attachments.

Apply the following weight changes to operating weight and static tipping load.