



Volvo Construction Equipment

# A25G, A30G

Volvo Articulated Haulers 25-29 t 320-360 hp



# A passion for performance

At Volvo Construction Equipment, we're not just coming along for the ride. Developing products and services that raise productivity – we are confident we can lower costs and increase profits for industry experts. Part of the Volvo Group, we are passionate about innovative solutions to help you work smarter – not harder.

## Helping you to do more.

Doing more with less is a trademark of Volvo Construction Equipment. High productivity has long been married to low energy consumption, ease of use and durability. When it comes to lowering life-cycle costs, Volvo is in a class of its own.

## Designed to fit your needs.

There is a lot riding on creating solutions that are suited to the particular needs of different industry applications. Innovation often involves high technology – but it doesn't always have to. Some of our best ideas have been simple, based on a clear and deep understanding of our customers' working lives.



## You learn a lot in 180 years.

Over the years, Volvo has advanced solutions that have revolutionized the use of construction equipment. No other name speaks Safety louder than Volvo. Protecting operators, those around them and minimizing our environmental impact are traditional values that continue to shape our product design philosophy.

## We're on your side.

We back the Volvo brand with the best people. Volvo is truly a global enterprise, one that is on standby to support customers quickly and efficiently – wherever they are.

## We have a passion for performance.



Volvo Trucks



Renault Trucks



Mack Trucks



UD Trucks



Volvo Buses



Volvo Construction Equipment



Volvo Penta



Volvo Financial Services

# Pure uptime

Get continuous production with this bigger, durable and superior machine – always available and ready to work. Count on superb reliability thanks to the machine's robust design, easy service access and outstanding Volvo dealer network. Guarantee pure uptime.

## Guaranteed durability

Increase your uptime using heavy-duty front and rear frames, hitch and wet disk brakes. Volvo proven durability and the support of extensive warranty options means you never need to worry about getting the job done. Strength and durability are hallmarks of the Volvo articulated hauler.



## Fifty years strong

Fifty years and fifty tonnes later, Volvo is the world's leading manufacturer of articulated haulers. We invented the concept and have been developing and building these machines for over 50 years – it has come a long way from its original 10 tonne articulated hauler. With proven success over the years, the machines include innovative technology and the renowned Volvo engine.



## Service access

With industry-leading access, servicing your machine is quick and easy. The front grill swings down, opening a service platform with anti-slip steps. The electric hood opens to 90 degrees, allowing full and safe access to the engine compartment.



## Volvo dealer network

The exclusive Volvo dealer network is there to support you whenever you need it. Volvo offers a number of services, local knowledge and global experience, including telematics machine monitoring – CareTrack™ and MATRIS™ – as well as superb parts availability.





# UPTIME



Get ready to work with the all new A25G/A30G. Designed for heavy hauling in severe off-road operation, the machine's long service life, quality, reliability and durability is everything you expect from a Volvo. Hauling is easier and more efficient.

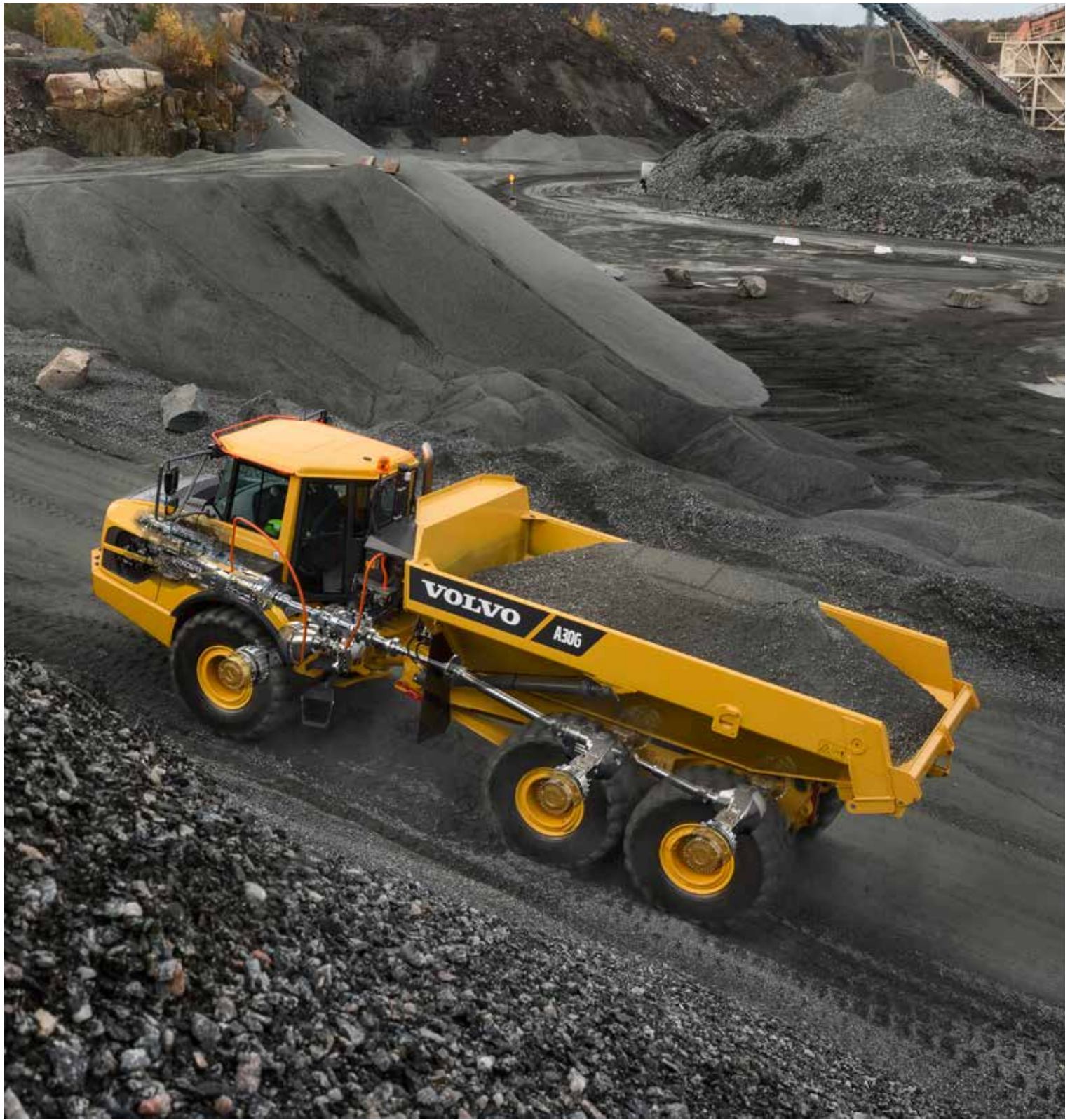

# FUEL EFFICIENCY GUARANTEED



The new A25G, A30G has guaranteed fuel efficiency, providing up to 10% more efficiency. The Volvo engine's lower idle speed delivers an additional fuel saving for the most efficient machine.

# Incredible efficiency

Improve your efficiency and move more for less. Excellent fuel efficiency, innovative technology and useful operational data tools help to control your maintenance costs and maximize your investment.

## Move more for less

The machine is optimized for efficiency featuring higher payload capabilities. Its smart design allows for more capacity while reducing fuel consumption so you can move more for less.



## Operational data

Receive valuable data to improve onsite efficiency and save costs. With intelligent systems from Volvo such as MATRIS™, CareTrack™ and the On Board Weighing system, you will optimize your production and minimise your operational costs.



## Volvo dynamic drive

Dynamic and predictive gear selection adapts to operating conditions, for improved comfort and fuel efficiency.



## Control your maintenance costs

The range of Customer Support Agreements offer preventive maintenance, total repairs and a number of uptime services. Volvo uses the latest technology to monitor machine operation and status, giving you advice to increase your profitability. By having a Customer Support Agreement you are in control of your service costs.



# Hit the targets

Hit your targets with the A25G, A30G. This machine features 100% off-road performance, proven Volvo technology and increased payload – contributing to sustainable operations, year after year.

## The best articulated hauler

The A25G, A30G machine delivers unbeatable off-road performance in its class with features including matched Volvo drivetrain, Automatic Traction Control including 100% differential locks, all-terrain bogie, hydro-mechanical steering.



## The right speed for the job

Ensure the right speed for your job using the retarders and dynamic Volvo Engine Brake to adapt your speed for maximum productivity and safety.



## Versatility

The A25G, A30G articulated hauler provides outstanding versatility so you can work in all seasons, terrains and applications for maximum utilization. With body building solutions and different chassis options you can tailor the machine to your jobsite.



## Load optimization

The optional On Board Weighing System guarantees the optimal load every cycle. This maximizes production, boosts fuel efficiency and reduces machine wear in all site conditions and operations.







# PRODUCTIVITY



Improve productivity and carry more in one go with increased payload.

# Get ready for heavy hauling

## OPERATOR'S CHOICE



Its comfortable cab and ease of operation, even in adverse conditions, makes operators choose this machine.

## New dump support system

The new dump support system increases stability and control in tough environments.

## Fifty years strong

Fifty years and fifty tonnes later, Volvo is the world's leading manufacturer of articulated haulers.

## New gradient controls

The new hill assist and dynamic Volvo Engine Brake features give you more control over your machine up or down steep gradients.

## The best articulated hauler

The ground-breaking A25G/A30G is the best articulated hauler on the market and the latest innovation from Volvo.



## UPTIME



Designed for heavy hauling in severe off-road operation, its long service life, quality, reliability and durability is everything you expect from a Volvo.

## FUEL EFFICIENCY GUARANTEED



Powered by the world-renowned Volvo engine delivers excellent fuel efficiency without compromising on power or performance.



### Service access

With industry-leading access, servicing your machine is quick and easy.

### Volvo dynamic drive

Gear shifting adapts dynamically to operating conditions, for improved comfort and fuel efficiency.

## PRODUCTIVITY



Move more tonnes per hour and give a 100% in all conditions.

### New econometer

The new econometer helps the operator to control the machine for extra productivity and safety.

### Versatility

With body building solutions and different chassis options you can tailor the machine to your jobsite.

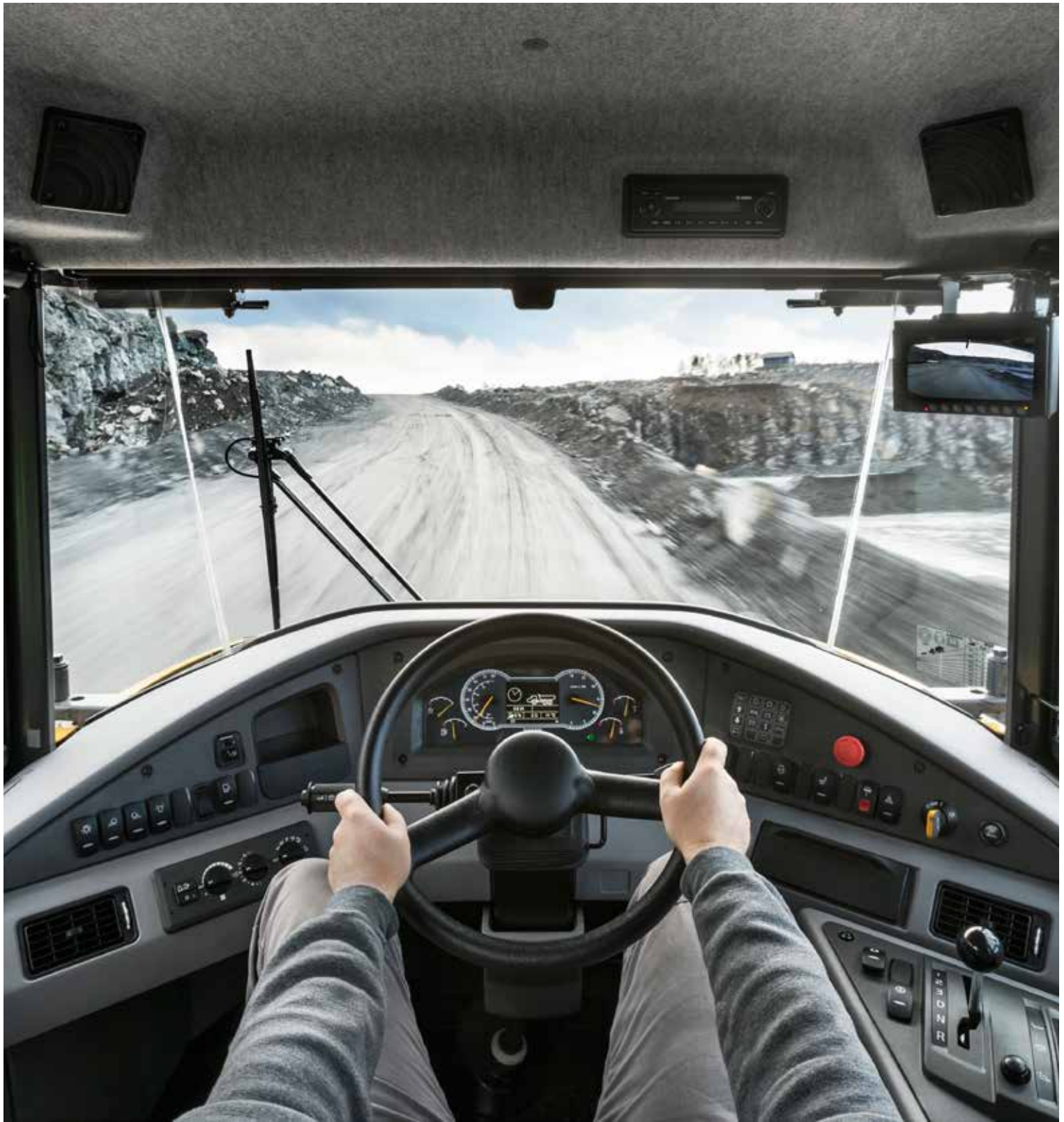

# OPERATOR'S CHOICE



When many other machines are onsite, most operators prefer the Volvo. Its comfortable cab and ease of operation, even in adverse conditions, makes operators choose this machine.

# Control in comfort

The A25G, A30G is the number one operator's choice because of its industry-leading spacious cab and comfortable work environment. Its superior comfort, control, ease of operation and safety appeals to operators, maintaining productivity all day, every day.

## Total operator control

The new dump support system, hill assist, dynamic Volvo Engine Brake control and econometer as well as load and dump brake, help the operator control the machine for extra productivity and safety in all conditions.



## Ease of operation

The ergonomic, comfortable controls are easy to understand and suit all operators, combined with automatic functions for increased ease of operation.



## Operator comfort

Feel comfortable and spend more time in the A25G/A30G. The centrally positioned operator, superior steering, excellent suspension, low noise levels, climate control, space and visibility, reduce operator fatigue for more effective operations.

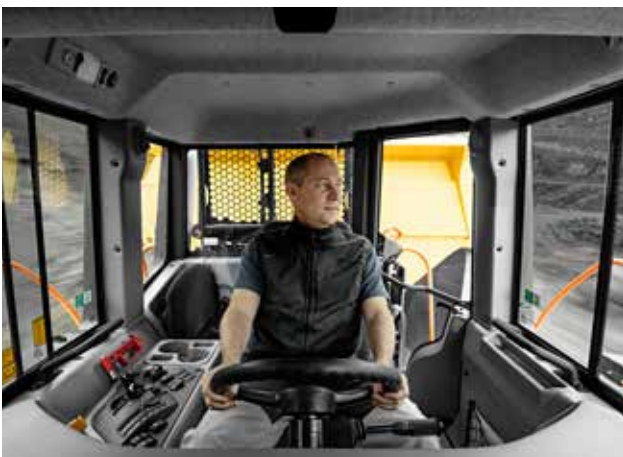

## Safety

A number of safety features such as superior visibility and efficient lighting help to keep the operator and people working around the machine safe in the most demanding working environments – whether it's the operator, trainers, mechanics or site workers.



# Volvo A25G, A30G in detail

## Engine

V-ACT, 11 liter, 6-cylinder in line turbocharged diesel engine with 4 valves per cylinder, overhead camshaft and electronically controlled unit injectors. It has wet replaceable cylinder liners and replaceable valve guides and valve seats.

### A25G

Engine model	Volvo	D11F
Max power - SAE J1995 Gross	kW	235
	hp	320
at engine speed	r/min	2 100
Flywheel power - ISO 9249, SAE J1349 Net	kW	234
	hp	318
at engine speed	r/min	2 100
Max torque - SAE J1995 Gross	Nm	1 950
Max torque - ISO 9249, SAE J1349 Net	Nm	1 942
at engine speed	r/min	1 100
Displacement	l	10.8

### A30G

Engine model	Volvo	D11F
Max power - SAE J1995 Gross	kW	265
	hp	360
at engine speed	r/min	2 000
Flywheel power - ISO 9249, SAE J1349 Net	kW	264
	hp	359
at engine speed	r/min	2 000
Max torque - SAE J1995 Gross	Nm	1 950
Max torque - ISO 9249, SAE J1349 Net	Nm	1 942
at engine speed	r/min	1 200
Displacement	l	10.8

## Electrical System

All cables, sockets and pins are identified. Cables are enclosed in plastic conduits and secured to main frame. Halogen lights. Prewired for options. Connectors meet IP67 standard for water-proofing as necessary.

		A25G	A30G
Voltage	V	24	24
Battery	V	2x12	2x12
Battery capacity	Ah	2x170	2x170
Alternator	kW/A	3.396/120	3.396/120
Starter motor	kW	9	9

## Drivetrain

Torque converter with built-in lock-up function.  
Transmission: Fully automatic Volvo PowerTronic planetary transmission with six forward gears and two reverse gears. The transmission has the ability to skip gears for fast and accurate gear selection.  
Dropbox: Volvo-developed, in-line design with high ground clearance and 100% longitudinal "dog clutch" type differential lock.  
Axles: Heavy duty, purpose built Volvo design with fully floating axle shafts, planetary type hub reductions and 100% dog clutch type diff-lock.  
Automatic traction control system (ATC).

		A25G	A30G
Torque converter		2.37:1	2.37:1
Transmission	Volvo	PT 2116	PT 2116
Dropbox	Volvo	IL1 ATC	IL1 ATC
Axles	Volvo	AHW56	AHW64

## Brake System

Fully hydraulic, wet multiple disc brakes with enclosed, forced oil-cooled multiple discs on all wheels. Two circuit brake system. Complies with ISO 3450 at total machine weight.  
Circuit division: One circuit for front axle and one for bogie axles.  
Parking brake: Spring-applied disc brake acting on the trailer unit propeller shaft. When the parking brake is applied, the longitudinal differential locked.  
Retarder: Service brake retarder function and Volvo Engine Brake (VEB).

## Steering System

Hydro-mechanical articulated steering, self compensating design.  
Two double-acting steering cylinders.  
Steering angle: 3,4 steering wheel turns lock-to-lock,  $\pm 45^\circ$ .  
Steering system, including secondary steering fulfills ISO 5010.

<b>Chassis</b>			
Frames: box type, heavy duty. High strength steel, robot welded. Rotating hitch: 100% maintenance free, fully sealed, with permanently greased tapered roller bearings.			
<b>Hydraulic system</b>			
Pumps: Four variable displacement piston pumps driven by the flywheel PTO. Two load-sensing used for steering and tipping and two electrical controlled used for fan, brake cooling and brake power supply. One ground-dependent piston pump for secondary steering mounted on the dropbox. Two return oil filters with magnetic cores provide effective oil filtration.			
		A25G	A30G
System max working pressure	MPa	25	25
<b>Cab</b>			
Mounted on rubber pads. Ergonomically designed. Easy entry and exit. Wide angle forward view. Operator centrally positioned above the front axle. Adjustable operators seat with retractable seat belt. Tilt/telescopic steering wheel. Ergonomically positioned controls. Filtered air. Optional climate control system. Operator communication system: Contronics. Large color display, user-friendly and easy-to-understand information, all vital machine functions are constantly monitored. Instructor seat with seat belt. Safety: ROPS/FOPS standards approved according to ISO3471, SAE J1040 / ISO3449, SAE J231.			
		A25G	A30G
Sound level in cab (ISO 6396) - LpA	dB(A)	72	72
External sound level (ISO 6395) - LwA	dB(A)	110	111
Internal sound level with sound kit: 70 dB(A) External sound level with sound kit: 108 dB(A)			
<b>Dumping System</b>			
Patented Load and Dump Brake. Dumping Cylinders: two single stage double acting cylinders.			
		A25G	A30G
Tipping angle	°	74	70
Tipping time with load	s	12	12
Lowering time	s	10	10

<b>Body</b>			
		A25G	A30G
<b>Plate thickness</b>			
Front	mm	6	6
Sides	mm	10	10
Bottom	mm	14	14
Chute	mm	14	14
<b>Material</b>		HB450 steel	HB450 steel
Yield strength	N/mm <sup>2</sup>	1 150	1 150
Tensile strength	N/mm <sup>2</sup>	1 350	1 350
<b>Load Capacity</b>			
		A25G	A30G
<b>Standard Body</b>			
Load capacity	kg	25 000	29 000
Body, struck	m <sup>3</sup>	12.1	13.9
Body, heaped 2:1	m <sup>3</sup>	15.3	17.8
<b>With overhung tailgate</b>			
Body, struck	m <sup>3</sup>	12.4	14.2
Body, heaped 2:1	m <sup>3</sup>	15.9	18.4

# Specifications

## REFILL CAPACITIES

		A25G	A30G
Crankcase	l	35	35
Fuel tank	l	380	380
Cooling system	l	48	48
Brake cooling system	l	35	35
Transmission	l	41	41
Dropbox	l	9	9
Axles, front/bogie	l	30/61	31/63
Hydraulic tank	l	137	137

## OPERATING WEIGHT UNLOADED

		A25G	A30G
Tires		23.5R25*	750/65R25**
Front	kg	12 700	12 950
Rear	kg	9 650	10 250
Total	kg	22 350	23 200
Payload	kg	25 000	29 000

Operating weight includes all fluids and operator

\*) A25G with tires 750/65R25, add 200 kg / axle

\*\*) A30G with tires 23,5R25, decrease 200 kg / axle

## SPEED

		A25G	A30G
<b>Forward</b>			
1	km/h	8.3	8.3
2	km/h	11.9	11.9
3	km/h	21.1	21.1
4	km/h	30.3	30.3
5	km/h	38.4	38.4
6	km/h	52.7	52.7
<b>Reverse</b>			
1	km/h	7.7	7.7
2	km/h	13.7	13.7

## TOTAL WEIGHT

		A25G	A30G
Tires		23,5R25*	750/65R25**
Front	kg	14 850	15 550
Rear	kg	32 500	36 650
Total	kg	47 350	52 200

\*) A25G with tires 750/65R25, add 200 kg / axle

\*\*) A30G with tires 23,5R25, decrease 200 kg / axle

## GROUND PRESSURE

		A25G	A30G	A25G	A30G
Tires		23.5R25	750/65R25	750/65R25	23.5R25
<b>Unloaded</b>					
Front	kPa	130	108	108	131
Rear	kPa	49	43	42	50
<b>Loaded</b>					
Front	kPa	157	130	125	157
Rear	kPa	166	152	137	184

## Excavator PASS MATCHING

	EC300	EC380	EC480	EC750
<b>Number of passes</b>				
A25G	10	6	5	3
A30G	8	8	6	4

Well matched, 4-6 buckets.

Excavator under capacity, 7 buckets or more.

Excavator undersized for optimum match.

## Wheel loader PASS MATCHING

	L120	L150	L180	L220	L250
<b>Number of passes</b>					
A25G	4	3	3	3	2
A30G	5	4	4	3	3

Well matched, 2-3 buckets.

Loader under capacity, 4 buckets or more.

Loader undersized for optimum match, reach might be an issue.



### DIMENSIONS

Pos	Unit	A25G	A30G
A	mm	10 218	10 296
A <sub>1</sub>	mm	4 954	4 954
A <sub>2</sub>	mm	5 736	5 811
B	mm	5 162	5 384
C	mm	3 356	3 366
C <sub>1</sub>	mm	1 772	1 772
D	mm	2 762	2 762
D <sub>1</sub>	mm	2 607	2 607
E	mm	1 209	1 209
F	mm	4 175	4 175
G	mm	1 670	1 670
H	mm	1 610	1 688
I	mm	609	609
J	mm	2 791	2 866
K	mm	2 103	2 183
L	mm	678	688
M	mm	6 529	6 562
N	mm	8 109	8 109
N <sub>1</sub>	mm	4 092	4 048
O	mm	2 776	2 976
P	mm	2 490	2 690
Q	mm	2 298	2 472
R	mm	519	524
R <sub>1</sub>	mm	633	639
S	mm	2 110	2 288
T	mm	3 094	3 196
U	mm	3 265	3 325
V	mm	2 258	2 216
W	mm	2 915	2 954
X	mm	455	466
X <sub>1</sub>	mm	581	592
X <sub>2</sub>	mm	660	680
Y	mm	2 258	2 216
Z	mm	2 915	2 954
a <sub>1</sub>	°	23.5	23.2
a <sub>2</sub>	°	74	70
a <sub>3</sub>	°	45	45

A25G: Unloaded machine with 23.5 R25

A30G: Unloaded machine with 750/65R25

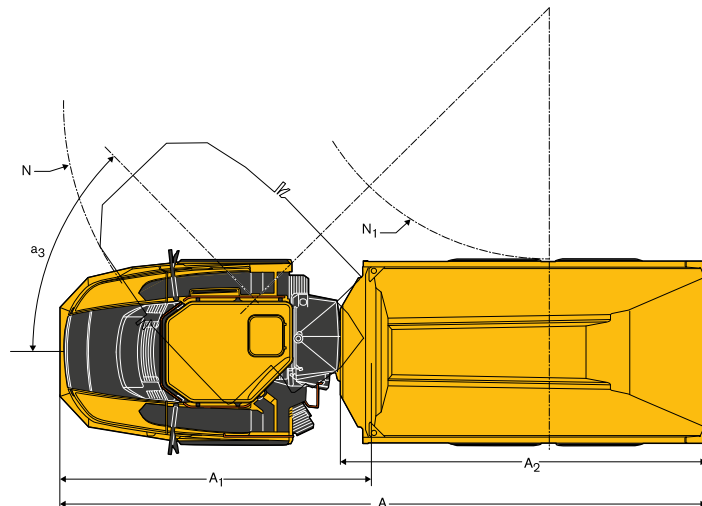
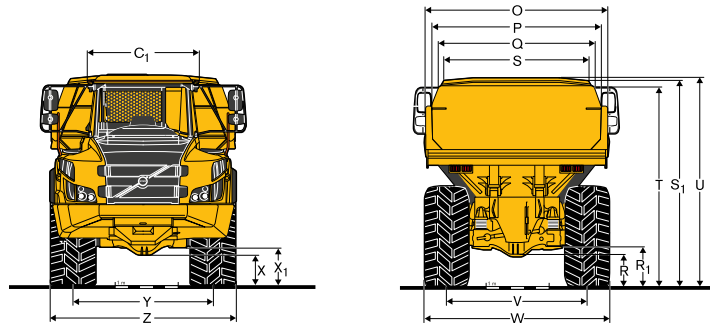
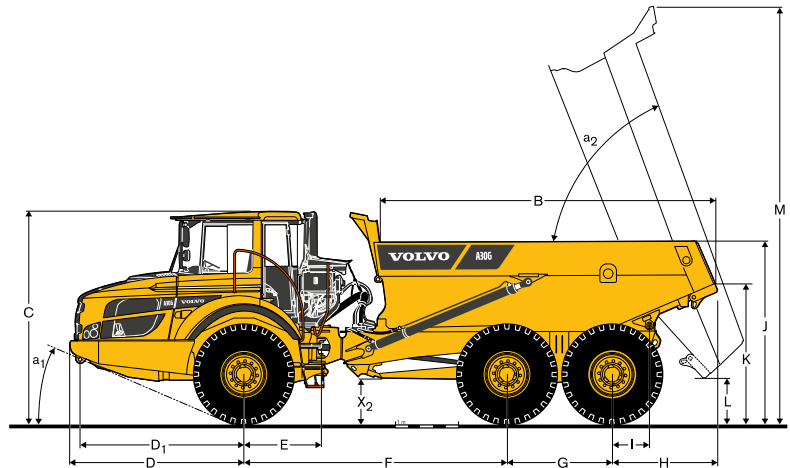

# Equipment

## STANDARD EQUIPMENT

	A25G	A30G
<b>Engine</b>		
Air pre-cleaner, cyclone type	•	•
Air pre-cleaner, oil-bath type	•	•
Air filter, heavy duty, EON	•	•
Engine heater, 120 V, USA	•	•
Engine heater, 240 V	•	•
Engine heater, diesel (Eberspächer)	•	•
Engine heater, diesel with separate tank	•	•
Engine auto shutdown	•	•
Engine shutdown timer	•	•
External emergency engine stop	•	•
Fuel filter, extra	•	•
High engine idle speed	•	•
<b>Electrical System</b>		
Headlights, LED	•	•
Warning beacon, LED	•	•
Working lights, halogen	•	•
Working lights, LED	•	•
Entrance light	•	•
Anti-theft system (pin code)	•	•
Rear view camera	•	•
Reverse alarm	•	•
CAN-BUS interface, extra	•	•
<b>Tires</b>		
23.5R25	•	-
750/65R25	-	•
<b>Cab</b>		
Noise reduction kit (fulfils 2000/14/EC)	•	•
Anchorage, operator's manual	•	•
Cab heating/ventilation timer	•	•
Cable kit, for cab heater 240 V	•	•
HEPA cab air filter	•	•
Bluetooth radio kit	•	•
Rear view mirrors, adjustable, el.heated	•	•
Seat belt XXL, non-retractable	•	•
Sun blinds, side windows	•	•
Universal key	•	•
Air suspended, heated, fully adjustable seat	•	•
Armrest for operator seat	•	•
Headrest for operator seat	•	•
Low profile cab	•	•
<b>Body</b>		
Body exhaust heating	•	•
Front spillguard, extra	•	•
Side extension, 200 mm	•	•
Side extension, light material	•	•
Tailgate, overhung, linkage-operated	•	•
Tailgate, overhung, wire-operated	•	•
Tailgate, underhung	•	•
Wear plates, 450 HB	•	•
Underground body	•	•

## STANDARD EQUIPMENT

	A25G	A30G
<b>Safety</b>		
Fire suppression system	•	•
Warning triangle	•	•
First aid kit and fire extinguisher	•	•
Fire extinguisher	•	•
Wheel chocks	•	•
<b>Service and Maintenance</b>		
Lube system, standard machine	•	•
Lube system, tailgate	•	•
Lubrication hose, ground level greasing	•	•
Tool kit	•	•
<b>Other</b>		
Siberian kit -40°C	•	•
On board weighing (OBW)	•	•
Arctic oil kit	•	•
CareTrack	•	•
Fast fuelling system	•	•
Jump start connector, NATO -type	•	•
Frame extension	•	•
Bogie extension	•	•

## OPTIONAL EQUIPMENT

	A25G	A30G
<b>Safety</b>		
Fire suppression system	•	•
Warning triangle	•	•
First aid kit and fire extinguisher	•	•
Fire extinguisher	•	•
Wheel chocks	•	•
<b>Engine</b>		
Air pre-cleaner, cyclone type	•	•
Air pre-cleaner, oil-bath type	•	•
Air filter, heavy duty, EON	•	•
Engine heater, 120 V, USA	•	•
Engine heater, 240 V	•	•
Engine heater, diesel (Eberspächer)	•	•
Engine heater, diesel with separate tank	•	•
Engine auto shutdown	•	•
Engine shutdown timer	•	•
External emergency engine stop	•	•
Fuel filter, extra	•	•
High engine idle speed	•	•

OPTIONAL EQUIPMENT		
	A25G	A30G
<b>Electrical system</b>		
Headlights, LED	•	•
Warning beacon, LED	•	•
Working lights, halogen	•	•
Working lights, LED	•	•
Entrance light	•	•
Anti-theft system (pin code)	•	•
Rear view camera	•	•
Reverse alarm	•	•
CAN-BUS interface, extra	•	•
<b>Cab</b>		
Noise reduction kit (fulfils 2000/14/EC)	•	•
Anchorage, operator's manual	•	•
Cab heating/ventilation timer	•	•
Cable kit, for cab heater 240 V	•	•
HEPA cab air filter	•	•
Bluetooth radio kit	•	•
Rear view mirrors, adjustable, el.heated	•	•
Seat belt XXL, non-retractable	•	•
Sun blinds, side windows	•	•
Universal key	•	•
Air suspended, heated, fully adjustable seat	•	•
Armrest for operator seat	•	•
Headrest for operator seat	•	•
Low profile cab	•	•

OPTIONAL EQUIPMENT		
	A25G	A30G
<b>Body</b>		
Body exhaust heating	•	•
Front spillguard, extra	•	•
Side extension, 200 mm	•	•
Side extension, light material	•	•
Tailgate, overhung, linkage-operated	•	•
Tailgate, overhung, wire-operated	•	•
Tailgate, underhung	•	•
Wear plates, 450 HB	•	•
Underground body	•	•
<b>Tires</b>		
23.5R25	-	•
750/65R25	•	-
<b>Service and maintenance</b>		
Lube system, standard machine	•	•
Lube system, tailgate	•	•
Lubrication hose, ground level greasing	•	•
Tool kit	•	•
<b>Other</b>		
Siberian kit -40°C	•	•
On board weighing (OBW)	•	•
Arctic oil kit	•	•
CareTrack	•	•
Fast fuelling system	•	•
Jump start connector, NATO -type	•	•
Frame extension	•	•
Bogie extension	•	•

## SELECTION OF VOLVO OPTIONAL EQUIPMENT

**Volvo fire suppression system**



**Fast fuelling**



**Heavy duty air filter**



**On board weighing**



**Entrance light**



**Rear view camera**



Not all products are available in all markets. Under our policy of continuous improvement, we reserve the right to change specifications and design without prior notice. The illustrations do not necessarily show the standard version of the machine.

**VOLVO**

**Volvo Construction Equipment**

[www.volvoce.com](http://www.volvoce.com)