



Cat[®] 259D3

COMPACT TRACK LOADER

FEATURES:

The Cat[®] 259D3 Compact Track Loader, with its vertical lift design, delivers extended reach and lift height for quick and easy truck loading. Its standard, suspended undercarriage system provides superior traction, flotation, stability and speed to work in a wide range of applications and underfoot conditions. The 259D3 features the following:

- **Industry leading sealed and pressurized cab option** provides a cleaner and quieter operating environment with excellent work tool visibility.
- **Available high-back, heated, air ride seat with seat mounted adjustable joystick controls** makes the D3 Series the industry leader in operator comfort.
- **High performance power train** provides maximum performance and production capability through the Electronic Torque Management system, standard two speed travel and an electronic hand/foot throttle with decel pedal capability.
- **High Flow hydraulic system** is available for applications that demand maximum hydraulic work tool performance.
- **Cat C3.3B engine and high performance power train** provide high engine horsepower and torque, allowing partial-throttle operation for lower sound levels and fuel consumption.
- **Cat "Intelligent Leveling" system** provides industry leading technology, integration, and available features such as dual direction self level, work tool return to dig, and work tool positioner.
- **Standard fully independent torsion axle suspension** combined with the optional Speed Sensitive Ride Control system improves operation on rough terrain, enabling better load retention, increased productivity and greater operator comfort.
- **Maximize machine capability and control** with optional Advanced Display providing on-screen adjustments for implement response, hystat response and creep control. Also features multi-language functionality with customizable layouts, security system and rearview camera.
- **Ground level access** to all daily service and routine maintenance points helps reduce machine downtime for greater productivity.
- **Broad range of performance matched Cat Work Tools** make the Cat Compact Track Loader the most versatile machine on the job site.

Specifications

Engine

Engine Model	Cat C3.3B DIT (turbo)	
Gross Power SAE J1995	55.4 kW	74.3 hp
Net Power SAE 1349	53.8 kW	72.1 hp
	54.2 kW†	72.7 hp†
Net Power ISO 9249	54.3 kW	72.8 hp
	54.8 kW†	73.5 hp†
Peak Torque at 1,600 rpm SAE J1995	265 N-m	195 lbf-ft
Displacement	3.3 L	203 in ³
Stroke	120 mm	4.7 in
Bore	94 mm	3.7 in

†Engine meeting Brazil MAR-1 and China Nonroad Stage III emission standards emits equivalent to U.S. EPA Tier 4 Interim and is offered only for Australia/New Zealand, Brazil, China, French Polynesia, Hong Kong, Macedonia and New Caledonia.

Weights*

Operating Weight	4076 kg	8,987 lb
------------------	---------	----------

*Operating Weight, Operating Specifications and Dimensions all based on 75 kg (165 lb) operator, all fluids, two speed, OROPS, 1730 mm (68 in) low profile bucket, 320 mm (12.6 in) tracks, dual flange front idler/single flange rear idler, standard flow hydraulics, mechanical suspension seat, no optional counterweights and manual quick coupler (unless otherwise noted).

Power Train

Travel Speed (Forward or Reverse)			
One Speed	9.5 km/h	5.9 mph	
Two Speed	13.7 km/h	8.5 mph	

Hydraulic System

Hydraulic Flow – Standard:			
Loader Hydraulic Pressure	23 000 kPa	3,335 psi	
Loader Hydraulic Flow	76 L/min	20 gal/min	
Hydraulic Power (calculated)	29 kW	39 hp	
Hydraulic Flow – High Flow:			
Loader Hydraulic Pressure	23 000 kPa	3,335 psi	
Loader Hydraulic Flow	112 L/min	30 gal/min	
Hydraulic Power (calculated)	43 kW	58 hp	



259D3 Compact Track Loader

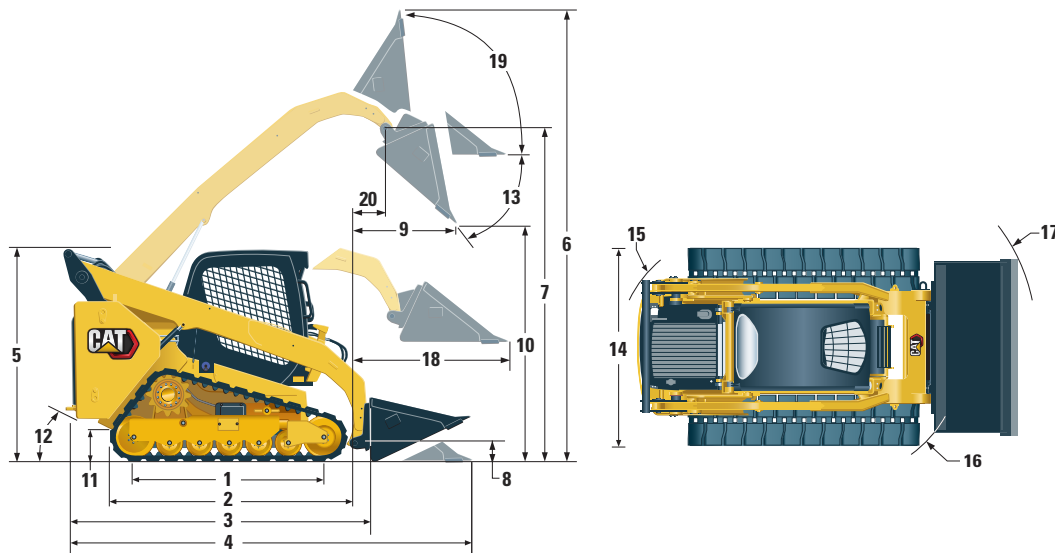

Dimensions*

1	Length of Track on Ground	1499 mm	59.0 in	12	Departure Angle	35°
2	Overall Length of Track	1999 mm	78.7 in	13	Maximum Dump Angle	52°
3	Length without Bucket	2767 mm	108.9 in	14	Vehicle Width (320 mm/12.6 in tracks)	1676 mm 66.0 in
4	Length with Bucket on Ground	3486 mm	137.3 in		Vehicle Width (400 mm/15.7 in tracks)	1755 mm 69.0 in
5	Height to Top of Cab	2111 mm	83.1 in	15	Turning Radius from Center – Machine Rear	1561 mm 61.5 in
6	Maximum Overall Height	3915 mm	154.1 in	16	Turning Radius from Center – Coupler	1392 mm 54.8 in
7	Bucket Pin Height at Maximum Lift	3075 mm	121.0 in	17	Turning Radius from Center – Bucket	2184 mm 86.0 in
8	Bucket Pin Height at Carry Position	198 mm	7.8 in	18	Maximum Reach with Arms Parallel to Ground	1305 mm 51.4 in
9	Reach at Maximum Lift and Dump	608 mm	23.9 in	19	Rack Back Angle at Maximum Height	87°
10	Clearance at Maximum Lift and Dump	2283 mm	89.9 in	20	Bucket Pin Reach at Maximum Lift	238 mm 9.4 in
11	Ground Clearance	226 mm	8.9 in			

Operating Specifications*

Rated Operating Capacity:		
35% Tipping Load	915 kg	2,010 lb
50% Tipping Load	1305 kg	2,870 lb
Rated Operating Capacity with Optional Counterweight		
Tipping Load	2610 kg	5,745 lb
Breakout Force, Tilt Cylinder	2252 kg	4,965 lb
Ground Contact Area (320 mm/12.6 in track)	0.96 m ²	1,483 in ²
Ground Contact Area (400 mm/15.7 in track)	1.19 m ²	1,848 in ²
Ground Pressure (320 mm/12.6 in track)	41.8 kPa	6.1 psi
Ground Pressure (400 mm/15.7 in track)	34.0 kPa	4.9 psi

Cab

ROPS	ISO 3471:2008
FOPS	ISO 3449:2005 Level I

Service Refill Capacities

Cooling System	14 L	3.7 gal
Engine Crankcase	11 L	3.0 gal
Fuel Tank	94 L	24.8 gal
Hydraulic System	50 L	13.2 gal
Hydraulic Tank	39 L	10.3 gal

Noise Level

Inside Cab**	83 dB(A)
Outside Cab***	103 dB(A)

**The declared dynamic operator sound pressure levels per ISO 6396:2008. The measurements were conducted with the cab doors and windows closed and at 70% of the maximum engine cooling fan speed. The sound level may vary at different engine cooling fan speeds.

***The labeled sound power level for the CE marked configurations when measured according to the test procedure and conditions specified in 2000/14/EC.

Air Conditioning System (if equipped)

The air conditioning system on this machine contains the fluorinated greenhouse gas refrigerant R134a (Global Warming Potential = 1430). The system contains 0.81 kg of refrigerant which has a CO₂ equivalent of 1.158 metric tonnes.

MANDATORY EQUIPMENT

- Hydraulics, Standard or High Flow
- Quick Coupler, Mechanical or Powered
- High Visibility Seat Belt, 50 mm (2 in) or 75 mm (3 in)
- EU Preparation Package
- Steel Imbed Rubber Track – 320 mm (12.6 in) or 400 mm (15.7 in)
- Dual Flange Front Idler/Single Flange Rear Idler or Triple Flange Front/Rear Idlers

PERFORMANCE PACKAGES

- Performance Package H1: *Standard Flow Hydraulics (No Self Level)*
- Performance Package H2: *Standard Flow Hydraulics, Dual Direction Electronic Self Level (Raise and Lower), Work Tool Return to Dig, Work Tool Positioner, and Electronic Snubbing (Raise and Lower)*
- Performance Package H3: *High Flow Hydraulics, Dual Direction Electronic Self Level (Raise and Lower), Work Tool Return to Dig, Work Tool Positioner, and Electronic Snubbing (Raise and Lower)*

STANDARD EQUIPMENT

ELECTRICAL

- 12 volt Electrical System
- 80 ampere Alternator
- Ignition Key Start/Stop Switch
- Lights: *Gauge Backlighting, Two Rear Tail Lights, Two Adjustable Front and Rear Halogen Lights, Dome Light*
- Backup Alarm
- Heavy Duty Battery, 850 CCA

OPERATOR ENVIRONMENT

- Advanced Display with Rearview Camera: *Full Color, 127 mm (5 in) LCD screen; Advanced Multi-operator Security System; On-screen Adjustments for Implement Response, Hystat Response, and Creep Control*
- Gauges: *Fuel Level, Hour Meter*
- Operator Warning System Indicators: *Air Filter Restriction, Alternator Output, Armrest Raised/Operator Out of Seat, Engine Coolant Temperature, Engine Oil Pressure, Glow Plug Activation, Hydraulic Filter Restriction, Hydraulic Oil Temperature, Park Brake Engaged, Engine Emission System*
- Adjustable Vinyl Seat
- Fold In Ergonomic Contoured Armrest
- Control Interlock System, when operator leaves seat or armrest raised: *Hydraulic System Disables, Hydrostatic Transmission Disables, Parking Brake Engages*
- ROPS Cab, Open, Tilt Up
- FOPS, Level I
- Top and Rear Windows
- Floor Mat
- Interior Rearview Mirror
- 12 volt Electric Socket
- Horn
- Hand (Dial) Throttle, Electronic
- Adjustable Joystick Controls
- Anti-theft Security System with 6-button Keypad
- Storage Compartment with Netting

COMFORT PACKAGES

- Open ROPS (C0): *Static Seat (No Foot Throttle, Headliner, Heater or Door)*
- Open ROPS (C1): *Foot Throttle, Headliner, Cup Holder, and choice of Seat (Mechanical Suspension or High Back, Heated, Air Ride Seat) (No Heater or Door)*
- Enclosed ROPS with Heater (C2): *Foot Throttle, Headliner, Heater and Defroster, Side Windows, Cup Holder, Radio Ready, choice of Seat (Mechanical Suspension or High Back, Heated, Air Ride Seat) and Door (Glass or Polycarbonate)*
- Enclosed ROPS with A/C (C3): *C2 + Air Conditioner*

POWER TRAIN

- Cat C3.3B, Turbo Diesel Engine
- Air Cleaner, Dual Element, Radial Seal
- S-O-SSM Sampling Valve, Hydraulic Oil
- Filters, Cartridge-type, Hydraulic
- Filters, Canister-type, Fuel and Water Separator
- Radiator/Hydraulic Oil Cooler (side-by-side)
- Spring Applied, Hydraulically Released Parking Brakes
- Hydrostatic Transmission, Two Speed Travel
- Suspension – Independent Torsion Axles (4)

OTHER

- Engine Enclosure, Lockable
- Extended Life Antifreeze, –36° C (–33° F)
- Machine Tie Down Points (6)
- Support, Lift Arm
- Hydraulic Oil Level Sight Gauge
- Radiator Coolant Level Sight Gauge
- Radiator, Expansion Bottle
- Cat ToughGuard™ Hose
- Auxiliary, Hydraulics, Continuous Flow
- Heavy Duty, Flat Faced Quick Disconnects with Integrated Pressure Release
- Split D-Ring to Route Work Tool Hoses Along Side of Left Lift Arm
- Electrical Outlet, Beacon
- Belly Pan Cleanout
- Variable Speed Demand Fan
- Product Link™ PL240, Cellular

259D3 Compact Track Loader

OPTIONAL EQUIPMENT

- Hand-Foot Style Controls
- External Counterweights
- Beacon, Rotating
- Engine Block Heater – 120V
- Oil, Hydraulic, Cold Operation
- Paint, Custom
- Product Link PL641, Cellular
- Speed Sensitive Ride Control
- Bluetooth® Radio with Microphone (AM/FM/Weather Band Receiver with USB and Auxiliary Input Jack)



For more complete information on Cat products, dealer services, and industry solutions, visit us on the web at www.cat.com

© 2019 Caterpillar
All rights reserved

Materials and specifications are subject to change without notice. Featured machines in photos may include additional equipment. See your Cat dealer for available options.

CAT, CATERPILLAR, LET'S DO THE WORK, their respective logos, "Caterpillar Yellow," the "Power Edge" and Cat "Modern Hex" trade dress as well as corporate and product identity used herein, are trademarks of Caterpillar and may not be used without permission.

AEHQ8219 (07-2019)
(S Am, AME, CIS,
APD-LRC Regions)

