

KOMATSU®

D155AX-8

Tier 4 Final Engine

CRAWLER DOZER

D155



Photos may include optional equipment.

NET HORSEPOWER

354 HP @ 1900 rpm
264 kW @ 1900 rpm

OPERATING WEIGHT

89,300 lb
40,506 kg

BLADE CAPACITY

12.3 yd³ 9.4 m³ SIGMADOZER
15.6 yd³ 11.9 m³ Full-U

WALK-AROUND

D155AX-8



Photos may include optional equipment.

NET HORSEPOWER

354 HP @ 1900 rpm
264 kW @ 1900 rpm

OPERATING WEIGHT

89,300 lb
40,506 kg

BLADE CAPACITY

12.3 yd³ 9.4 m³ SIGMADOZER
15.6 yd³ 11.9 m³ Full-U



OUTSTANDING PRODUCTIVITY & FUEL ECONOMY

Innovative SIGMADOZER blade reduces digging resistance and smoothly rolls material up for increased blade loads.

Blade capacity:
12.3 yd³ 9.4 m³

Auto shift transmission with lock-up torque converter improves fuel consumption and performance.

Komatsu SAA6D140E-7 variable geometry turbocharged and after-cooled 15.24 liter diesel engine is EPA Tier 4 Final emissions certified.

- Heavy duty Selective Catalytic Reduction (SCR) system
- Diesel Exhaust Fluid (DEF) system
- Komatsu Diesel Particulate Filter (KDPF) system
- Heavy duty cooled Exhaust Gas Recirculation (EGR) system
- Electronic control system - seamless to the operator
- Komatsu Variable Geometry Turbocharger (KVGT) system
- Heavy duty High Pressure Common Rail (HPCR) fuel injection system

Fluid neutral or better

Fuel & DEF total consumption is less than fuel consumed by prior model.

Komatsu Diesel Particulate Filter (KDPF) and Selective Catalytic Reduction (SCR) systems reduce particulate matter and NOx while providing automatic regeneration that does not interfere with daily operation.

Komatsu Variable Geometry Turbocharger (KVGT) uses a hydraulic actuator to provide optimum air flow under all speed and load conditions.

Komatsu Auto Idle Shutdown helps reduce excessive idle time.

Rear hydraulics (standard)

Rear view monitoring system (standard)

Advanced diagnostic system continuously monitors machine operation and vital systems to identify machine issues, assists with troubleshooting, and minimizes down time.

KOMTRAX® can send information to a secure website including machine location, SMR, error codes, cautions, maintenance items, fuel usage, fuel levels, DEF levels, ambient conditions and much more.

Integrated ROPS cab features:

- Large, quiet, and pressurized cab
- Excellent visibility with integrated ROPS structure
- Air suspension heated seat with high capacity
- New roof mounted A/C condenser



Hydrostatic Steering System (HSS) provides smooth, quick, and powerful control in various ground conditions. (Counter-rotation is available when in neutral.)

Complete operator control

- Palm Command Control System (PCCS)
- Automatic/manual shift selectable modes
- New cancel auto downshift in manual mode added to operator menu
- Shift pattern preset function
- Blade auto pitch mode
- New ripper auto return
- Power and Economy modes

Extra-low machine profile provides excellent machine balance and low center of gravity.

Large color monitor:

- Easy-to-read large 7" high-resolution multi-color monitor
- Easy-to-use multiple choice pull-down menus
- Easy-to-use onboard diagnostics without requiring a laptop
- Ecology guidance

K-bogie undercarriage system improves traction, component durability, and operator comfort.

Parallel Link Undercarriage System (PLUS) (optional):

- Increases wear life up to two times
- Rotating bushings eliminate the cost and downtime for bushing turns
- Up to 40% lower undercarriage maintenance costs

** All comparisons are to the prior model, unless otherwise stated.

PERFORMANCE FEATURES

KOMATSU NEW ENGINE TECHNOLOGIES

New Tier 4 Final Engine

The Komatsu SAA6D140E-7 engine is EPA Tier 4 Final emissions certified and provides exceptional performance while reducing fuel consumption. Based on Komatsu proprietary technologies developed over many years, this new diesel engine reduces nitrogen oxides (NOx) by more than 80% when compared to Tier 4 interim levels. Through the in-house development and production of engines, electronics, and hydraulic components, Komatsu has achieved great advancements in technology, providing high levels of performance and efficiency in virtually all applications.

Technologies Applied to New Engine

Heavy-duty aftertreatment system

This new system combines a Komatsu Diesel Particulate Filter (KDPF) and Selective Catalytic Reduction (SCR). The SCR NOx reduction system injects the correct amount of DEF at the proper rate, thereby decomposing NOx into non-toxic water (H₂O) and nitrogen gas (N₂).

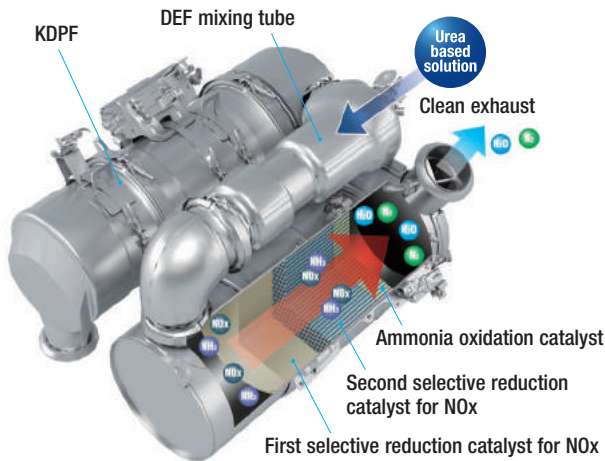

Heavy-duty cooled Exhaust Gas Recirculation (EGR) system

The system recirculates a portion of exhaust gas into the air intake and lowers combustion temperatures, thereby reducing NOx emissions. EGR gas flow has been decreased for Tier 4 Final with the addition of SCR technology. The system achieves a dynamic reduction of NOx, while helping reduce fuel consumption below Tier 4 Interim levels.

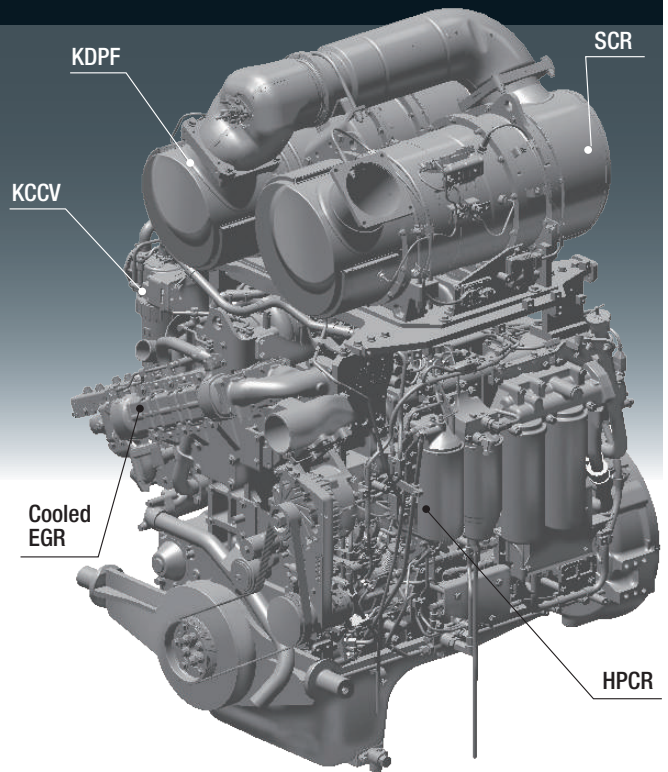
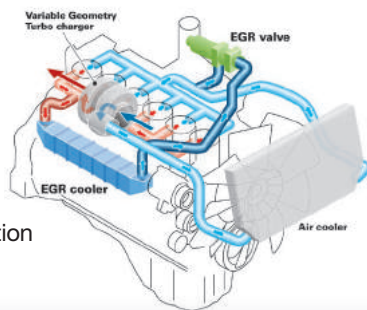

Advanced Electronic Control System

The electronic control system performs high-speed processing of all signals from sensors installed in the vehicle providing total control of equipment in all conditions of use. Engine condition information is displayed via an on-board network to the monitor inside the cab, providing necessary information to the operator. Additionally, managing the information via KOMTRAX helps customers keep up with required maintenance.

Komatsu Variable Geometry Turbocharger (KVGT) system

The KVGT system features proven Komatsu design hydraulic technology for variable control of air-flow and supplies optimal air according to load conditions. The upgraded version provides better exhaust temperature management.

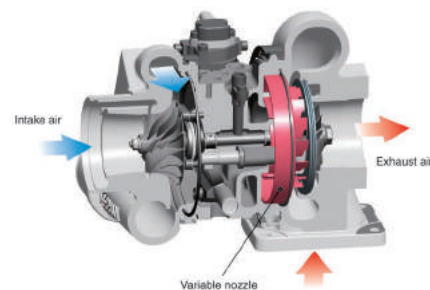

Komatsu Auto Idle Shutdown

Komatsu auto idle shutdown automatically shuts the engine down after idling for a set period of time to reduce unnecessary fuel consumption and exhaust emissions. The amount of time before the engine is shutdown can be easily programmed from 5 to 60 minutes.

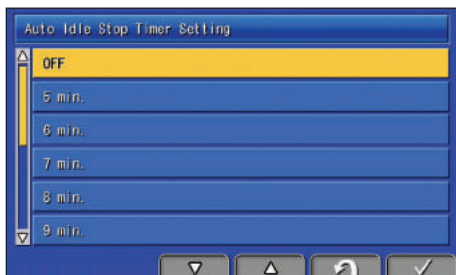

Secondary Engine Shutdown Switch

A secondary switch is at the side of the front console to shut down the engine.



Heavy-Duty High-Pressure Common Rail (HPCR) Fuel Injection System

The system is designed to achieve an optimal injection of high-pressure fuel by means of computerized control, providing close to complete combustion to reduce PM emissions. While this technology is already used in current engines, the new system uses high pressure injection, thereby reducing both PM emissions and fuel consumption over the entire range of engine operating conditions. The Tier 4 Final engine has advanced fuel injection timing for reduced fuel consumption and lower soot levels.

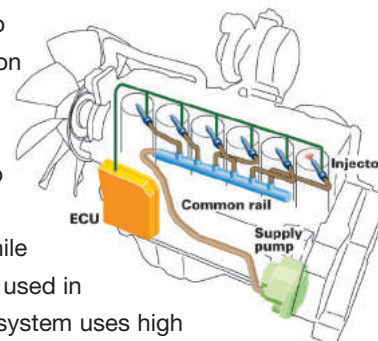

Hydraulically Driven Cooling Fan

The engine cooling fan rotation speed is electronically controlled. The fan rotation speed depends on engine coolant, powertrain oil and hydraulic oil temperatures. The higher the temperature the higher the fan speed. This system increases fuel efficiency, reduces the operating noise levels and requires less horsepower than a belt driven fan. The fan is manually reversible by the operator for periodic cleaning.



PERFORMANCE FEATURES

D155AX-8

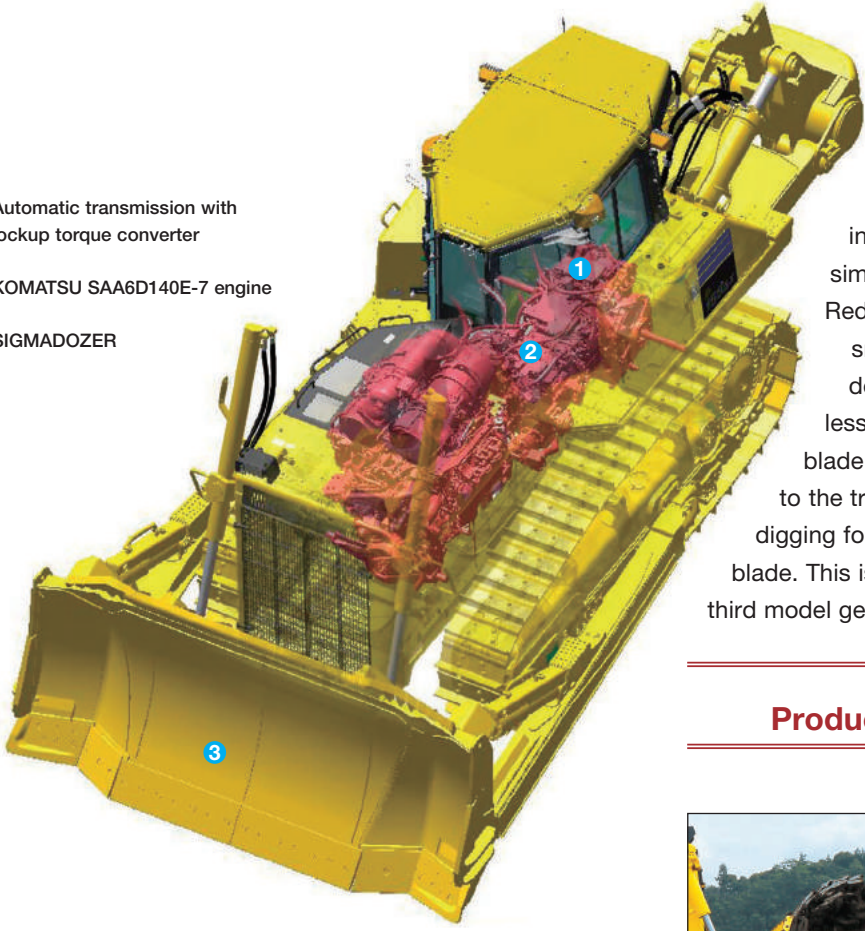

- 1 Automatic transmission with lockup torque converter
- 2 KOMATSU SAA6D140E-7 engine
- 3 SIGMADOZER

Innovative SIGMADOZER

Based on a completely new digging theory, SIGMADOZER dramatically improves dozing performance and increases productivity. A new frontal design concept adopted for digging and rolling up at the center of the blade increases soil holding capacity, simultaneously reducing sideways spillage. Reduced digging resistance produces smoother flow of earth, enabling the dozing of larger quantities of soil with less power. In addition, adoption of a new blade linkage system holds the blade closer to the tractor for improved visibility, enhanced digging force and reduced lateral sway of the blade. This is the new generation blade now in its third model generation.

New Fuel Efficient Bulldozer

New D155AX-8 has achieved both high levels of productivity and fuel economy through usage of SIGMADOZER and automatic transmission with lockup torque converter.

SIGMADOZER



PRODUCTION: 15% increase

Automatic transmission with lockup torque converter

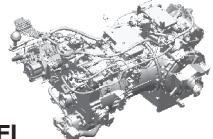

FUEL CONSUMPTION: 10% reduction

FUEL EFFICIENCY: 25% increase

Compared to machine with Semi-U blade and manual shift transmission

Production increased by 15%

Compared to conventional Semi-U blade

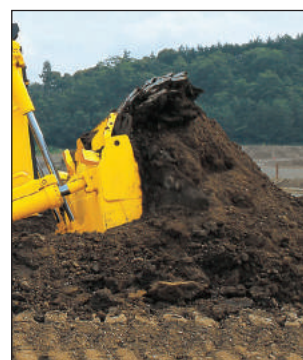

SIGMADOZER



Semi-U blade

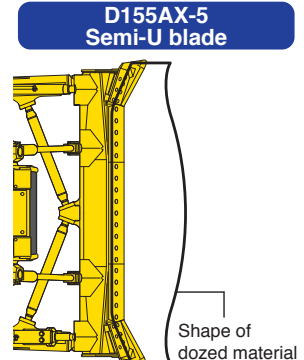
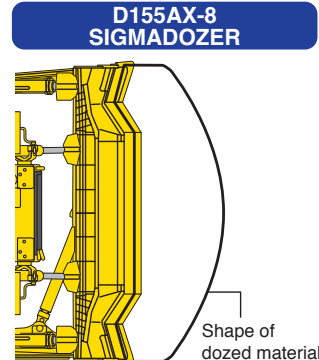

Automatic Transmission with Lockup Torque Converter

A sharp reduction in fuel consumption and greater power train efficiency is achieved by the automatic gearshift transmission and lock up torque converter. The automatic gearshift transmission selects the optimal gear range depending on the working conditions and load placed on the machine. This means the machine is designed to operate at maximum efficiency. (Manual gearshift mode is selectable with a switch).

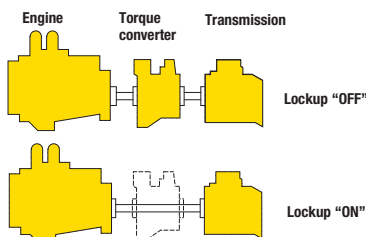

Fuel consumption reduced by 10%

Compared to machine with manual shift transmission

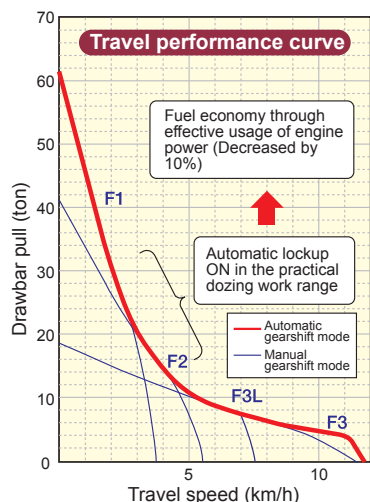

Lockup mechanism of torque converter is automatically actuated to transfer engine power directly to the transmission in usual dozing speed range. Locking up the torque converter eliminates loss of horsepower by 10%. Because the electronically controlled engine is extremely efficient, a decrease in fuel consumption is realized while also maintaining machine power.

Automatic/Manual Gearshift Selectable Mode

Automatic or manual gearshift modes can be selected with ease to suit the work at hand by simply pressing the switch on the multi-monitor (selection in neutral).

Automatic gearshift mode

The mode for general dozing. When a load is applied, the gear automatically shifts down, and when the load is off, it automatically shifts up to a set maximum gear speed. This mode economizes both fuel and production where the torque converter lockup mechanism is actuated according to load, automatically selecting the optimum gear speed.

Manual gearshift mode

The mode for dozing and ripping rough ground. When enabled, the gear automatically shifts down, but does not shift up when the load is off. The operator can specify whether the auto shift down function is enabled or disabled by selection in the monitor.

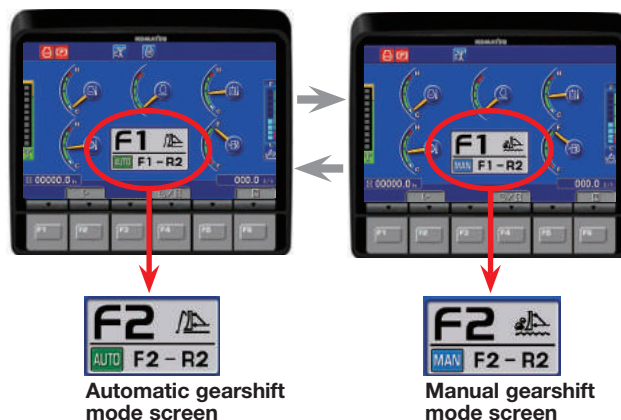

CONTROL FEATURES

Palm Command Electronic Controlled Travel Control Joystick

Palm command travel joystick provides the operator with a relaxed posture and superb fine control without operator fatigue. Transmission gear shifting is simplified with thumb push buttons.

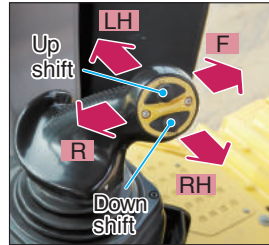

Gearshift Pattern Preset Function

When the gearshift pattern is set to either <F1-R2>, <F2-R2> or <F2-R3L> in automatic gearshift mode, the gear is automatically shifted, reducing round trip repetition work time and operator's effort.



Automatic gearshift mode

F1-R1 MODE
Press DOWN switch ↑ Press UP switch ↓

F1-R2 MODE
Press DOWN switch ↑ Press UP switch ↓

F2-R2 MODE
Press DOWN switch ↑ Press UP switch ↓

F2-R3L MODE

Manual gearshift mode

F1-R1 MODE
Press DOWN switch ↑ Press UP switch ↓

F1-R2 MODE
Press DOWN switch ↑ Press UP switch ↓

F2-R2 MODE

Palm Command Electronic Controlled Blade/Ripper Control Joystick

Electronically-controlled palm command joystick is equipped for blade/ripper control. Combined with the highly reliable Komatsu hydraulic system, superb control is the result.

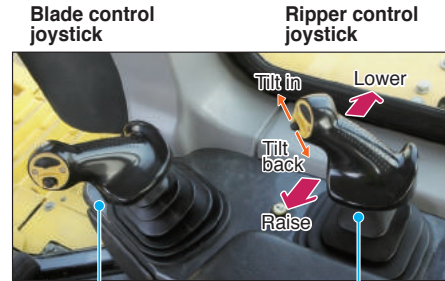

Blade control joystick

Ripper control joystick

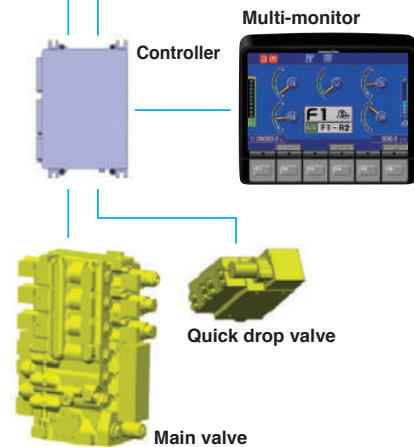

Electronic Controlled Modulation Valve (ECMV) Controlled Transmission and Brakes

Controller automatically adjusts each clutch engagement depending on travel conditions, providing smooth shockless clutch engagement, improved component life and operator ride comfort.

Hydrostatic Steering System (HSS) –Smooth, Powerful Turning

The engine power is transmitted to both tracks without power interruption on the inside track for smooth, powerful turns. Counter-rotation while in neutral is available for minimum turning radius providing excellent maneuverability.



Auto-pitch Mode*

To reduce operator effort and increase operating efficiency the new auto blade pitch mode sets blade pitch position between digging and dump positions while dozing. By pressing the auto-pitch switch it will toggle the pitch position from digging to dump position with no additional lever movements. The blade pitch control can be set through the monitor to automatically return to the digging position when reverse is selected.

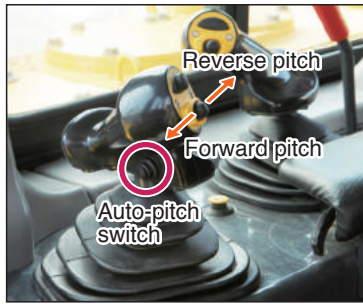

* Requires dual tilt dozer

Ripper Auto-return

The ripper control lever is new, ergonomic and incorporates an auto-return function that will automatically raise the ripper so the operator is less fatigued at the end of the day. The function starts when travel lever is moved to reverse position.

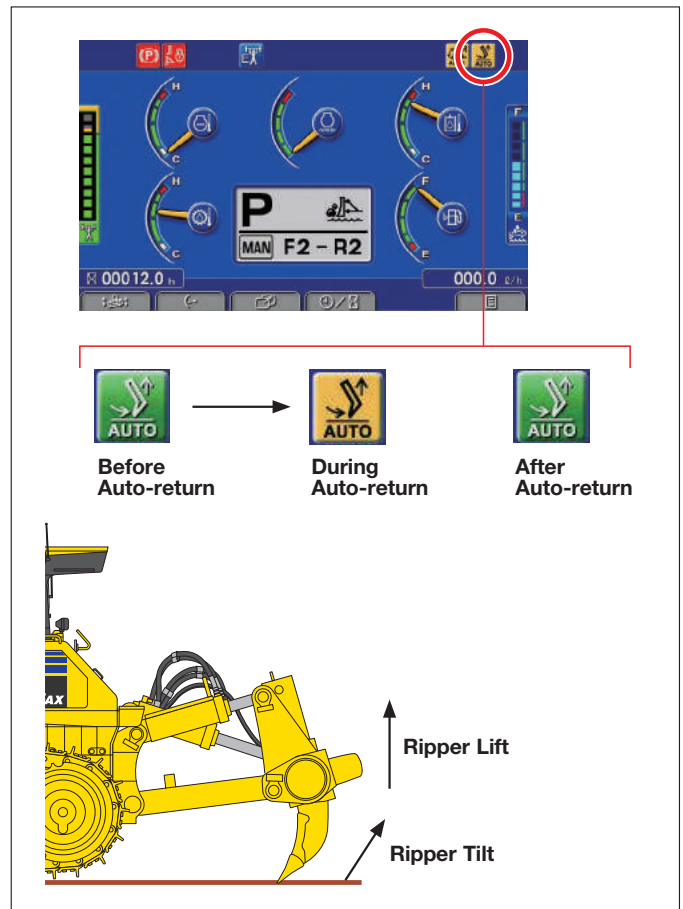
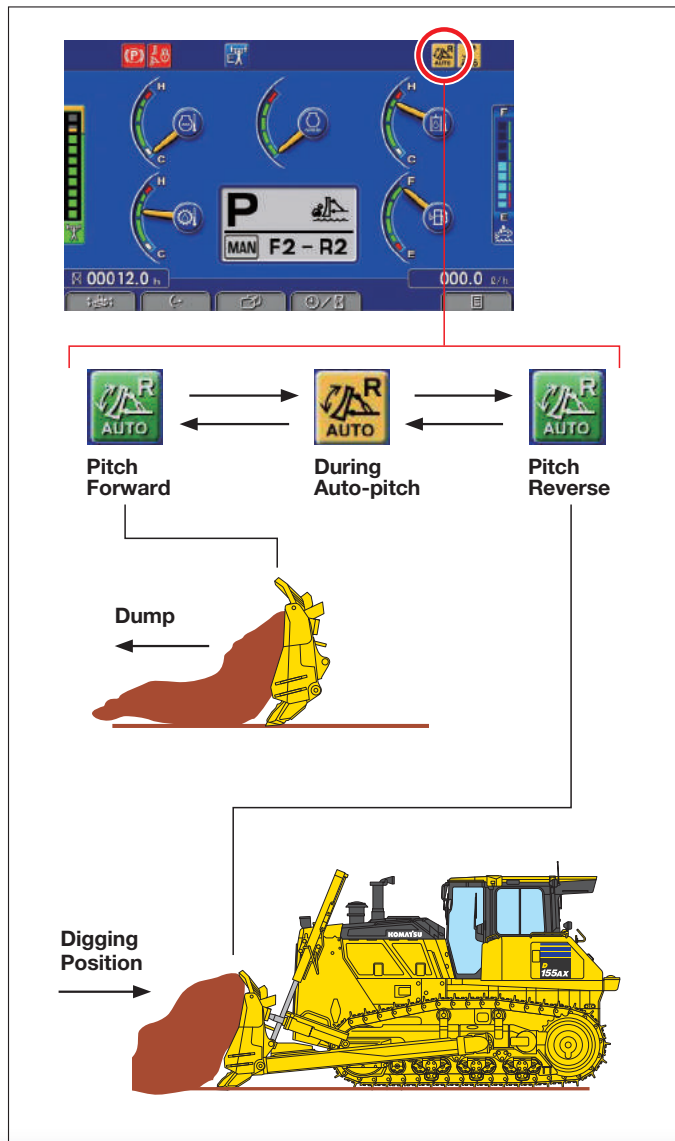
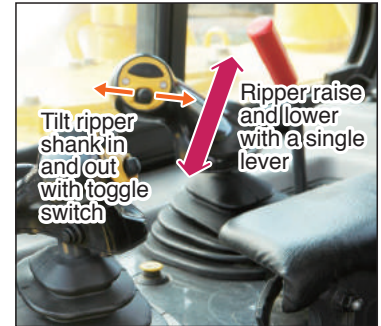

WORKING ENVIRONMENT

D155AX-8



Integrated ROPS Cab

The D155AX-8 has a tall and long integrated ROPS cab with large glass windows for outstanding visibility. High rigidity and superb sealing performance greatly reduce noise and vibration for the operator and helps prevent dust from entering the cab. The standard air-suspension seat positions the operator comfortably. Cab meets OSHA/MSHA/ROPS and FOPS Level 2 standards.



Rear View Monitoring System (standard)

The operator can view the rear of the machine with a color monitor screen.

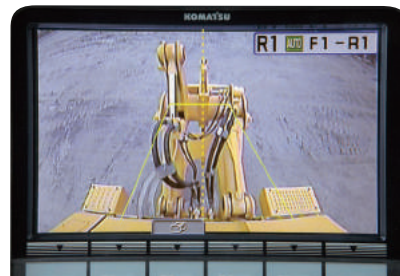

Comfortable Ride with Cab Damper Mounting

The D155AX-8's cab mount uses a cab damper which provides excellent shock and vibration absorption capacity with its long stroke. Cab damper mounts soften shocks and vibration while traveling over adverse conditions, which conventional mounting systems are unable to match. The cab damper spring isolates the cab from the machine body, suppressing vibration and providing a quiet, comfortable operating environment.

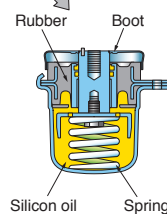

Ripper Visibility

Ripper cylinders were reduced from four to two, greatly improving rear visibility during ripping. Also, expanded ripper movement offers a wider range of operation.

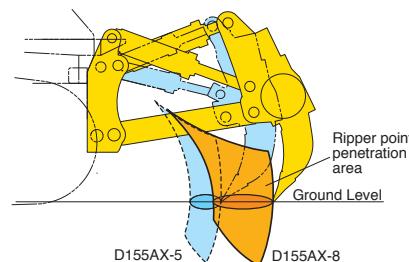

MAINTENANCE FEATURES

DEF Tank

A large tank volume extends operating time before refilling and is installed at the operator cab left platform for ease of access.



Parallel Link Undercarriage System (PLUS) (Optional)

Undercarriage wear life is increased by up to two times and the cost of a bushing turn and downtime is eliminated. Undercarriage maintenance costs are lowered by up to 40%.

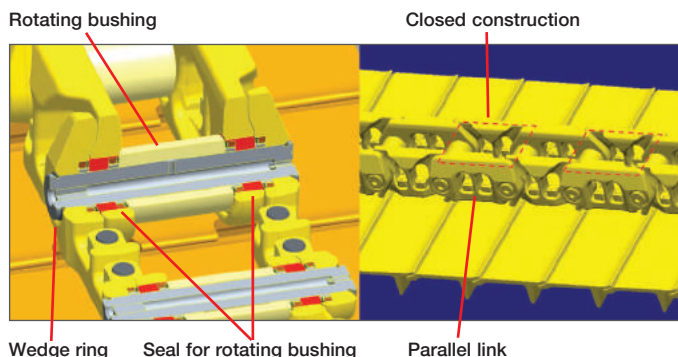

Flat Face O-ring Seals

Flat face O-ring seals are used to securely seal all hydraulic hose connections and to help prevent oil leakage.

Wide Core Cooling System

In addition to improved engine compartment sealing, a wide core cooling system is standard. Radiator, oil cooler and charge air cooler use large square-wave fins spaced at 6 fins per inch. This allows more material to pass through, which helps self-cleaning and reduces maintenance.

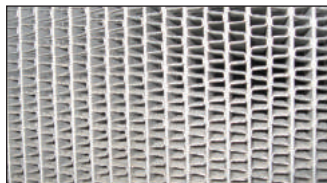

Battery Disconnect Switch

A standard battery disconnect switch allows a technician to disconnect the power supply before servicing the machine.



Maintenance Records

Machine monitor stores and displays maintenance records including scheduled service interval and remaining service hours.

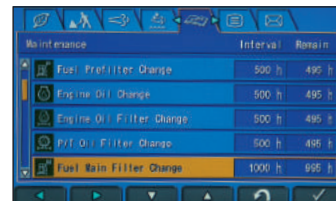

Easy Radiator Cleaning

The radiator can be cleaned by utilization of the reversible, hydraulically driven cooling fan. The fan can be reversed from inside the cab by simply activating via the monitor to reverse. Hinged double doors open wide for access to radiator.



Oil Pressure Checking Ports

Pressure checking ports for power train components are centralized to promote quick and simple diagnosis.

Concentrated Engine Check Points

The opening area is large when the gull-wing engine side covers are opened, facilitating engine daily checks and maintenance. Side covers have been changed to a thick one-piece structure with a bolt-on latch to improve durability.



KOMATSU PARTS & SERVICE SUPPORT



Every new Komatsu Tier 4 Final construction machine is covered.

The Komatsu CARE program covers all new Komatsu Tier 4 Final construction equipment, whether rented, leased or purchased. For the first 3 years or 2,000 hours, whichever occurs first, you'll receive:

- Regular service at 500, 1,000, 1,500 and 2,000-hr. intervals
- DEF tank breather element replacement at 1,000 hours
- DEF and CCV filters replacement at 2,000 hours
- 50-point inspection by factory-trained technician at each scheduled interval
- Technician labor
- Fluids, oils, coolant, filters, SCR screen, tank breather and parts
- Technician travel to and from your equipment location

Plus two complimentary scheduled KDPF exchanges and SCR system service for 5 years-no hours limits.*

Service will be performed by a Komatsu Distributor and only Komatsu genuine fluids and filters will be used.

Komatsu CARE® services are available from every Komatsu Distributor in the U.S. and Canada.



Komatsu CARE® – Extended Coverage

- Extended Coverage can provide peace of mind by protecting customers from unplanned expenses that effect cash flow
- Purchasing extended coverage locks-in the cost of covered parts and labor for the coverage period and helps turn these into fixed costs



* Some exclusions apply. Please contact your Komatsu distributor for specific program details.



Komatsu Parts Support

- 24/7/365 to fulfill your parts needs
- 9 parts Distribution Centers strategically located across the U.S. and Canada
- Distributor network of more than 300 locations across U.S. and Canada to serve you
- Online part ordering through Komatsu eParts
- Remanufactured components with same-as-new warranties at a significant cost reduction



Komatsu Oil and Wear Analysis (KOWA)

- KOWA detects fuel dilution, coolant leaks, and measures wear metals
- Proactively maintain your equipment
- Maximize availability and performance
- Can identify potential problems before they lead to major repairs
- Reduce life cycle cost by extending component life

KOMTRAX EQUIPMENT MONITORING

GET THE WHOLE STORY WITH
KOMTRAX[®]

✓ **WHAT**

- KOMTRAX is Komatsu's remote equipment monitoring and management system
- KOMTRAX **continuously monitors and records** machine health and operational data
- Information such as fuel consumption, utilization, and a detailed history **lowering owning and operating cost**

✓ **WHEN**

- Know when your machines are **running or idling** and make decisions that will improve your fleet utilization
- Detailed movement records ensure you know when and where your equipment is moved
- Up to date records allow you to **know when maintenance is due** and help you plan for future maintenance needs

✓ **WHERE**

- KOMTRAX data **can be accessed virtually anywhere** through your computer, the web or your smart phone
- Automatic alerts keep fleet managers up to date on the latest machine notifications

✓ **WHO**

- KOMTRAX is **standard** equipment on all Komatsu construction products



✓ **WHY**

- Knowledge is power - **make informed decisions** to manage your fleet better
- Knowing your idle time and fuel consumption will help maximize your machine efficiency
- **Take control of your equipment** - any time, anywhere



KOMTRAX[®]

For construction and compact equipment.

KOMTRAX Plus[™]

For production and mining class machines.

SPECIFICATIONS



ENGINE

Model.....Komatsu SAA6D140E-7**
 Type.....4-cycle, water-cooled, direct injection
 Aspiration.....Komatsu Variable Geometry
 Turbocharged, air-to-air aftercooled, cooled EGR
 Number of cylinders.....6
 Bore x stroke.....140 mm x 165 mm **5.51" x 6.50"**
 Piston displacement.....15.24 ltr **930 in³**
 Governor.....Mid-range, electronic
 Horsepower
 SAE J1995.....Gross 268 kW **360 HP**
 ISO 9249 / SAE J1349*.....Net 264 kW **354 HP**
 Rated rpm.....1900 rpm
 Fan drive type.....Hydraulic
 Lubrication system
 Method.....Gear pump, force lubrication
 Filter.....Full-flow

*Net horsepower at the maximum speed of radiator cooling fan.....239 kW **320 HP**

**EPA Tier 4 Final emissions certified



TORQFLOW TRANSMISSION

Komatsu's automatic TORQFLOW transmission consists of a water-cooled, 3-element, 1-stage, 1-phase, torque converter with lockup clutch, and a planetary gear, multiple-disc clutch transmission which is hydraulically actuated and force-lubricated for optimum heat dissipation. Equipped with gearshift lock lever and neutral safety switch.

Travel speed	Forward	Reverse
1st	3.8 km/h 2.4 mph	4.6 km/h 2.9 mph
2nd	5.6 km/h 3.5 mph	6.8 km/h 4.2 mph
3rd L	7.5 km/h 4.7 mph	9.2 km/h 5.7 mph
3rd	11.6 km/h 7.2 mph	14.0 km/h 8.7 mph

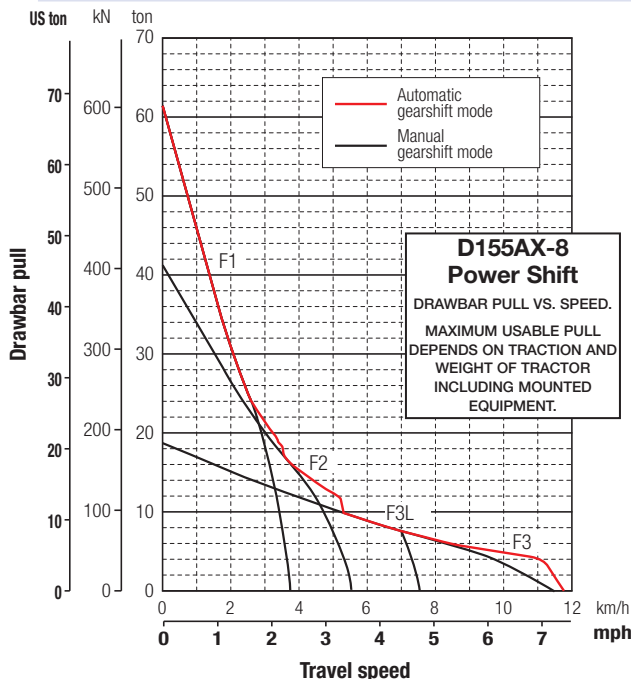

FINAL DRIVES

Double-reduction, spur and planetary final drives increase tractive effort. Segmented sprockets are bolt-on for easy in-the-field replacement.



STEERING SYSTEM

PCCS lever controls for all directional movements. Pushing the PCCS lever forward results in forward machine travel, while pulling it rearward reverses the machine. Simply tilt the PCCS lever to the left to make a left turn. Tilt it to the right for a right turn.

Hydrostatic steering system (HSS) is powered by steering planetary units and an independent hydraulic pump and motor. Counter-rotation turns are also available. Wet, multiple-disc, pedal-controlled service brakes are spring-actuated and hydraulically released. Gearshift lock lever also applies parking brakes.

Minimum turning radius 2.14 m **7'0"**



UNDERCARRIAGE

Suspension Oscillation-type with equalizer bar and forward mounted pivot shafts
 Track roller frame Monocoque, high-tensile-strength steel construction

K-Bogie undercarriage

Lubricated track rollers are resiliently mounted the track frame with a bogie suspension system whose oscillating motion is cushioned by rubber pads.

Track shoes

Lubricated tracks. Unique dust seals for preventing entry of foreign abrasives into pin-to-bushing clearance for extended service. Track tension easily adjusted with grease gun.

Number of shoes (each side) 42
 Grouser height 80 mm **3.1"**
 Shoe width (standard/maximum) 610 mm **24"/710 mm 28"**
 Ground contact area 39955 cm² **6,193 in²**
 Ground pressure (tractor only) 80.3 kPa 0.82 kg/cm² **11.6 psi**
 Number of track rollers (each side) 7
 Number of carrier rollers (each side) 2



SERVICE REFILL CAPACITIES

Fuel tank.....625 ltr **165 U.S. gal**
 Coolant.....104 ltr **27.5 U.S. gal**
 Engine oil.....37 ltr **9.8 U.S. gal**
 Damper.....1.5 ltr **0.4 U.S. gal**
 Transmission, bevel gear, steering system.....90 ltr **23.8 U.S. gal**
 Final drive (each side).....31 ltr **8.2 U.S. gal**
 DEF tank.....39 ltr **10.3 U.S. gal**
 Hydraulic oil capacity.....95 ltr **25.1 U.S. gal**



OPERATING WEIGHT (APPROXIMATE)

Tractor weight.....32 700 kg **72,100 lb**
 Including rated capacity of lubricant, coolant, full fuel tank, operator, and standard equipment (including ROPS cab).

Operating weight.....40 506 kg **89,300 lb**
 Including strengthened SIGMADOZER, giant ripper, ROPS cab, operator, standard equipment, rated capacity of lubricant, coolant, and full fuel tank.

Ground pressure.....99.5 kPa 1.01 kg/cm² **14.4 psi**

D155AX-8



DIMENSIONS

A	4060 mm	13'4"
B	2140 mm	7'0"
C	3385 mm	11'1"
D	1850 mm	6'1"
E	3275 mm	10'9"
F	8420 mm	27'7"
G	2745 mm	9'0"
H	1240 mm	4'1"
I	950 mm	3'1"
J	3390 mm	11'1"

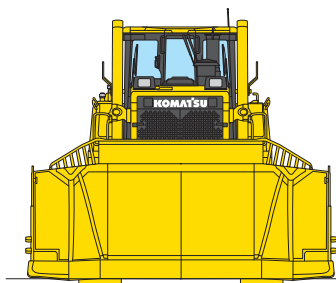
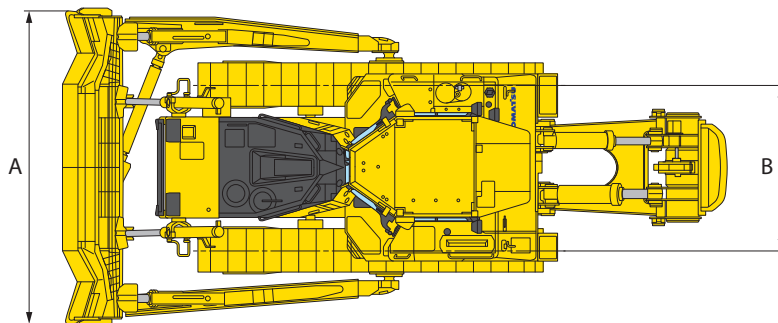

Ground clearance: 500 mm **1'8"**

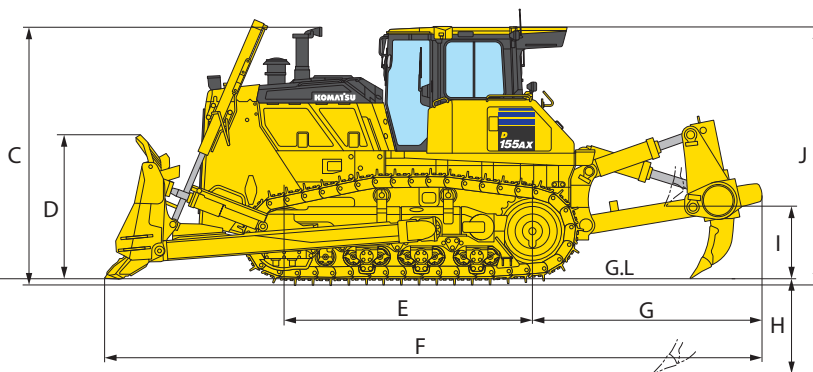

HYDRAULIC SYSTEM

Closed-center load sensing system (CLSS) designed for precise and responsive control, and for efficient simultaneous operation.

Hydraulic control unit:

All spool control valves externally mounted beside the hydraulic tank.

Variable piston pump with capacity (discharge flow) of 325 L/min **85.9 U.S. gal** for steering and 180 L/min **47.6 U.S. gal** for implement at rated engine rpm.

Relief valve setting

- for implement 27.5 MPa 280 kg/cm² **3,980 psi**
- for steering 38.2 MPa 390 kg/cm² **5,550 psi**

Control valves:

Spool control valve for SIGMADOZER, Semi-U tilt dozer and Full-U tilt dozer.

- Positions: Blade lift Raise, hold, lower, and float
- Blade tilt Right, hold, and left

Spool control valve for variable digging angle multi-shank ripper and giant ripper.

- Positions: Ripper lift Raise, hold, and lower
- Ripper tilt Increase, hold, and decrease
- Hydraulic cylinders Double-acting, piston

	Number of cylinders	Bore
Blade Lift	2	110 mm 4.33"
Blade Tilt	1	160 mm 6.30"
Ripper Lift	1	180 mm 7.09"
Ripper Tilt	1	200 mm 7.87"

Hydraulic oil capacity (refill):

SIGMADOZER	95.0 ltr 25.1 U.S. gal
Semi-U tilt dozer	95.0 ltr 25.1 U.S. gal
U-tilt dozer	95.0 ltr 25.1 U.S. gal

Ripper equipment (additional volume):

Multi-shank ripper	37 ltr 9.8 U.S. gal
Giant ripper	37 ltr 9.8 U.S. gal



DOZER EQUIPMENT

Use of high-tensile-strength steel in moldboard for strengthened blade construction. Blade tilt hose piping is mounted inside the dozer push arm to protect from damage.

	Overall Length With Dozer	Blade Capacity	Blade Length x Height	Max. Lift Above Ground	Max. Drop Below Ground	Max. Tilt Adjustment	Additional Weight
Strengthened SIGMADOZER*	6320 mm 20'9"	9.4 m ³ 12.3 yd³	4060 mm x 1850 mm 13'4" x 6'1"	1315 mm 4'4"	676 mm 2'3"	870 mm 2'10"	5410 kg 11,930 lb
Full-U Tilt Dozer*	6785 mm 22'3"	11.9 m ³ 15.6 yd³	4225 mm x 1790 mm 13'10" x 5'10"	1245 mm 4'1"	590 mm 1'11"	920 mm 3'0"	5680 kg 12,520 lb
Semi-U Tilt Dozer*	6370 mm 20'11"	9.4 m ³ 12.3 yd³	4130 mm x 1790 mm 13'7" x 5'10"	1245 mm 4'1"	590 mm 1'11"	860 mm 2'10"	5010 kg 11,040 lb

* Dual Tilt and Power Pitch Dozer



STANDARD EQUIPMENT FOR BASE MACHINE*

- Air cleaner, double element with dust indicator
 - Alternator, 140 ampere/24V
 - Backup alarm
 - Batteries, 200 Ah/2 x 12V
 - Battery disconnect switch
 - Blade lift cylinders with double dust seal
 - Color monitor, LCD
 - Decelerator pedal
 - Engine hood
 - Engine idle auto shutdown with adjustable timer
 - Engine intake centrifugal precleaner
 - Engine, gull-wing side covers
 - Engine shutdown secondary switch
 - Exhaust pipe with raincap
 - Fast fuel provision
 - Fenders
 - Front pull hook
 - Fuel pre-filter and primary filter
 - Grid heater starting aid in cold weather
 - High mount foot rests
 - Horn, warning
 - Hydraulic driven radiator cooling fan with manual reverse clean mode
 - Hydraulics for dual tilt and pitch dozer
 - Hydraulics for ripper VGR/MSR
 - KOMTRAX® Level 5
 - K-bogie undercarriage
 - Komatsu Diesel Particulate Filter (KDPF)
 - Komatsu Variable Geometry Turbocharger (KVTG)
 - Komatsu Selective Catalytic Reduction (SCR)
 - Locks, filler caps and covers
 - Oil pressure check ports for power train
 - PM service connector
 - Radiator mask, double door, heavy-duty, hinged, perforated
 - Radiator reserve tank
 - Rear cover
 - ROPS cab (1420 kg, **3,131 lb**)**
 - Air conditioner/heater/defroster
 - Pressurized
 - Condenser remote mounted
 - Cab accessories
 - 12V power supply (2 ports)
 - Cup holder
 - Rearview mirror
 - Rear view monitoring (1 camera)
 - AM/FM Radio w/remote AUX plug (3.5 mm)
 - Lunch box holder
 - Work lights
 - 2 front, hood mounted
 - 2 front, cab mounted
 - 2 rear, fender mounted
 - 2 rear, cab mounted
 - 1 rear, for ripper point
 - Seat, air suspension, fabric, heated, low back, rotates 12.5° to right, headrest
 - Seat belt, 76 mm **3"**, retractable
 - Seat belt indicator
 - Sealed electrical connectors
 - Starting motor, 11.0 kW/24V
 - Steering system:
 - Hydrostatic Steering System (HSS)
 - Torque converter with auto lock-up
 - Track roller guards, end sections
 - Track shoe assembly
 - Sealed and lubricated
 - 610 mm **24"** extreme service shoes
 - Transmission with auto/manual shift modes
 - Underguards, heavy duty
 - Hinged belly pans
 - Water separator, fuel
 - Wide core cooling package, 6 fins per inch spacing
- * Dozer assembly and rear mounted equipment are not included in base machine standard equipment
- ** Cab meets OSHA/MSHA ROPS and FOPS Level 2 standards

Note: Machine does not support aftermarket grade control installations (Topcon/Trimble).



OPTIONAL EQUIPMENT

■ Shoes

Shoes, single grouser	Additional weight	Ground contact area	Shoes, single grouser	Additional weight	Ground contact area
660 mm 26" extreme service	+240 kg +530 lb	43230 cm ² 6,700 in²	660 mm 26" PLUS extreme service	+819 kg +1,806 lb	43230 cm ² 6,700 in²
710 mm 28" moderate service	No additional	46505 cm ² 7,208 in²	710 mm 28" PLUS extreme service	+1029 kg +2,269 lb	46505 cm ² 7,208 in²
610 mm 24" PLUS extreme service	+569 kg +1,254 lb	39955 cm ² 6,193 in²			

■ Variable multi-shank ripper

- Additional weight (including hydraulic control unit): 3760 kg **8,290 lb**
- Beam length: 2320 mm **7'7"**
- Hydraulically-controlled parallelogram-type ripper with three shanks. Digging angle infinitely adjustable. Standard digging angle*: 49°
- Maximum digging depth: 900 mm **2'11"**
- Maximum lift above ground: 950 mm **3'1"**

■ Variable giant ripper

- Additional weight (including hydraulic control unit): 2440 kg **5,380 lb**
- Beam length: 1400 mm **4'7"**
- Hydraulically-controlled parallelogram-type ripper with one shank. Digging angle infinitely adjustable. Standard digging angle*: 49°
- Maximum digging depth: 1240 mm **4'1"**
- Maximum lift above ground: 950 mm **3'1"**

* Measured with ripper point on ground and shank vertical.

■ Other

- HD Counterweight 9-plate with rigid drawbar, 3568 kg **7,860 lb**
- Sigma push group (bladeless) for Allied blade

■ Dozer Equipment

- SIGMADOZER®
- Full-U
- Semi-U



ALLIED MANUFACTURER'S ATTACHMENTS (SHIPPED LOOSE)

- Guarding - Medford
 - Front sweeps covered bullnose 578 kg **1,275 lb**
 - Front sweeps covered bullnose plus cab roof/AC guard 794 kg **1,750 lb**
- Hinged cab rear screen 61 kg **135 lb**
- Hinged cab side screens 75 kg **165 lb**
- Tank guards 612 kg **1,350 lb**
- Hydraulic winch with drawbar - Allied H12E 1800 kg **4,000 lb**
- Manual angle power tilt blade - Rockland 6473 kg **14,270 lb**

AESS869-02

©2015 Komatsu America Corp.

Printed in USA

AD06(3K)OTP

06/15 (EV-1)

KOMATSU®

Note: All comparisons and claims of improved performance made herein are made with respect to the prior Komatsu model unless otherwise specifically stated.

www.komatsuamerica.com

Komatsu America Corp. is an authorized licensee of Komatsu Ltd. Materials and specifications are subject to change without notice

KOMATSU®, Komatsu Care® and KOMTRAX® are registered trademarks of Komatsu Ltd.

All other trademarks and service marks used herein are the property of Komatsu Ltd., Komatsu America Corp. or their respective owners or licensees.