

KOMATSU®

PC490LC-11

EPA Tier 4 Final Engine

Australia & New Zealand Specifications

HYDRAULIC EXCAVATOR



Photos may include optional equipment.

NET HORSEPOWER

268 kW / 359 HP @ 1900 rpm

OPERATING WEIGHT

47,890 – 49,680 kg

BUCKET CAPACITY

1.45 – 2.7 m³

PC490LC

WALK-AROUND

PC490LC-11



Photos may include optional equipment.

NET HORSEPOWER

268 kW/ 359 HP @ 1900 rpm

OPERATING WEIGHT

47,890 – 49,680 kg

BUCKET CAPACITY

1.45 – 2.7 m³

PERFORMANCE, DURABILITY AND FUEL ECONOMY

A large machine design with a reinforced undercarriage provides high lift capacity, lateral stability and added durability.

Enhanced Power Mode with increased hydraulic flow and new Tier 4 Final engine technology improves performance and fuel efficiency.

A powerful Komatsu SAA6D125E-7 engine provides a net output of 268 kW 359 HP. This engine is EPA Tier 4 Final emissions certified.

Komatsu Variable Geometry Turbocharger (KVGT) uses a hydraulic actuator to provide optimum air flow under all speed and load conditions.

Komatsu Diesel Particulate Filter (KDPF) and Selective Catalytic Reduction (SCR) system reduce particulate matter and NOx while providing automatic regeneration that does not interfere with daily operation.

Large displacement high efficiency pumps provide high flow output at lower engine speed, improving efficiency.

Two boom mode settings provide power mode for maximum digging force or smooth mode for fine grading operations.

Komatsu's Closed-centre Load Sensing System (CLSS) provides quick response and smooth operation to z productivity.

KOMTRAX® equipped machines can send location, SMR and operation maps to a secure website or smart phone utilising wireless technology. Machines also relay error codes, cautions, maintenance items, fuel & Diesel Exhaust Fluid (DEF) levels, and much more.

Large LCD colour monitor panel:

- 7" high resolution screen
- Provides "Ecology-Guidance" for fuel efficient operation
- Enhanced attachment control

Rearview monitoring system (standard)

Six working modes are designed to match engine speed, pump delivery, and system pressure to the application. An enhanced power mode is available to provide improved performance in high production applications.



Enhanced working environment

- High back, heated air suspension operator seat with adjustable arm rests
- Integrated ROPS cab design
- Cab meets ISO Level 1 Operator Protective Guard (OPG) top guard
- Aux jack and (2) 12V power outlets

Komatsu designed and manufactured components

Hydraulically driven variable speed fan is temperature controlled to reduce parasitic load on the engine to improve fuel consumption and can be manually reversed to simplify cooler maintenance.

Handrails (standard) located on the machine upper structure provide a convenient work area in front of the engine.

Lockable single pole battery isolation switch allows a technician to disconnect the power supply before servicing the machine.

Heavy duty boom design with large one piece castings provides increased strength and durability.

Komatsu Auto Idle Shutdown helps reduce nonproductive engine idle time and reduces operating costs.

Operator Identification System records KOMTRAX® machine operation and application data for up to 100 individual ID codes.

PERFORMANCE FEATURES

KOMATSU NEW ENGINE TECHNOLOGIES

New Tier 4 Final Engine

The Komatsu SAA6D125E-7 engine is EPA Tier 4 Final emissions certified and provides exceptional performance while reducing fuel consumption. Based on Komatsu proprietary technologies developed over many years, this new diesel engine reduces nitrogen oxides (NOx) by more than 80% when compared to Tier 4 interim levels. Through the in-house development and production of engines, electronics, and hydraulic components, Komatsu has achieved great advancements in technology, providing high levels of performance and efficiency in virtually all applications.

Technologies Applied to New Engine

Heavy-duty aftertreatment system

This new system combines a Komatsu Diesel Particulate Filter (KDPF) and Selective Catalytic Reduction (SCR). The SCR NOx reduction system injects the correct amount of Diesel Exhaust Fluid (DEF) at the proper rate, thereby decomposing NOx into non-toxic water vapour (H₂O) and nitrogen gas (N₂).

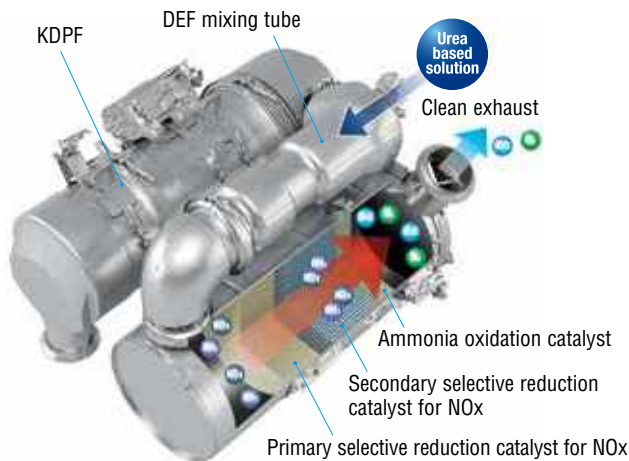

Heavy-duty cooled Exhaust Gas Recirculation (EGR) system

The system recirculates a portion of exhaust gas into the air intake and lowers combustion temperatures, thereby reducing NOx emissions. EGR gas flow has been decreased for Tier 4 Final with the addition of SCR technology. The system achieves a dynamic reduction of NOx, while helping reduce fuel consumption below Tier 4 Interim levels.

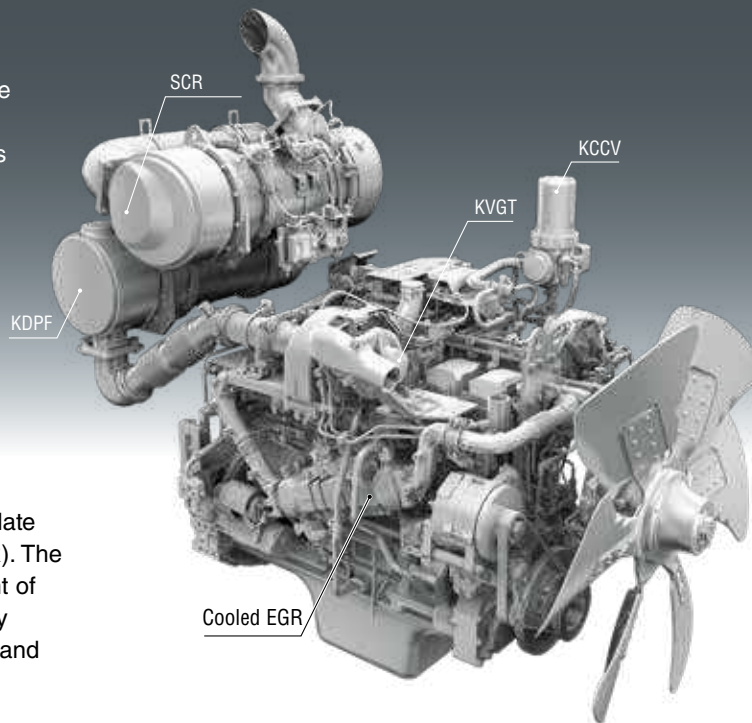
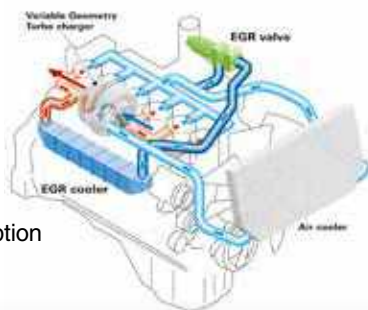

Advanced Electronic Control System

The electronic control system performs high-speed processing of all signals from sensors installed in the vehicle providing total control of equipment in all conditions of use. Engine condition information is displayed via an on-board network to the monitor inside the cab, providing necessary information to the operator. Additionally, managing the information via KOMTRAX helps customers keep up with required maintenance.

Komatsu Variable Geometry Turbocharger (KVG) system

The KVG system features proven Komatsu design hydraulic technology for variable control of air-flow and supplies optimal air according to load conditions. The upgraded version provides better exhaust temperature management.



Komatsu Auto Idle Shutdown

Komatsu auto idle shutdown automatically shuts the engine down after idling for a set period of time to reduce unnecessary fuel consumption and exhaust emissions.



Heavy-Duty High-Pressure Common Rail (HPCR) Fuel Injection System

The system is designed to achieve an optimal injection of high-pressure fuel by means of computerised control, providing close to complete combustion to reduce PM emissions. While this technology is already used in current engines, the new system uses high pressure injection, thereby reducing both PM emissions and fuel consumption over the entire range of engine operating conditions.

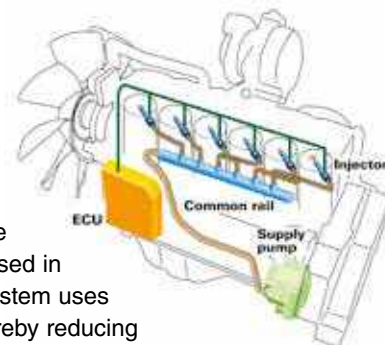

The Tier 4 Final engine has advanced fuel injection timing for reduced fuel consumption and lower soot levels.



PERFORMANCE FEATURES

Enhanced Productivity

The PC490LC-11's enhanced P Mode provides more hydraulic flow and increases productivity.

Productivity

Up to 13% increase

(compared to the PC450LC-8 in standard P Mode)

P mode (90° swing and loading onto truck)

- | | |
|------------------------------------|---------------------------------|
| 1 Large counterweight | 6 Reinforced centre frame |
| 2 High capacity swing bearing | 7 HD carrier rollers and idlers |
| 3 Reinforced track links and shoes | 8 Reinforced crawler frames |
| 4 Large final drive | 9 Reinforced revolving frame |
| 5 HD sprockets | 10 Track roller guards |
| | 11 Deck guard |
| | 12 Centre frame swivel guard |

Increased Work Efficiency

Large digging force

With the one-touch Power Max. function digging force has been further increased. (8.5 seconds of operation)

Maximum arm crowd force (ISO)

200 kN(20.4t) ➔ **214 kN(21.8t) 7% UP**
(with Power Max.)

Maximum bucket digging force (ISO)

256 kN(26.1t) ➔ **275 kN(28.0t) 7% UP**
(with Power Max.)

Measured with Power Max. function, 3400 mm arm and ISO rating

Faster arm cycle speeds

Two return hoses improve arm cylinder hydraulic flow for faster arm out performance.

Two boom mode settings for boom function

- Smooth boom mode provides easy operation for gathering material or scraping down.
- Power boom mode maximises digging force for more effective excavating.



PC490LC-11

Hydraulic Variable Speed Fan

The electronic control system sets the rotation speed of the cooling fan according to the coolant, hydraulic oil, and ambient temperatures; effectively uses the engine output to reduce wasteful fuel consumption; and reduces noise during low-speed fan operation.



Efficient Hydraulic System

The PC490LC-11 uses a Closed Centre Load Sensing (CLSS) Hydraulic System that improves fuel efficiency and provides quick response to the operator's demands. The PC490LC-11 also incorporates new technology to enhance the engine and hydraulic pump control. This total control system matches the engine and hydraulics at the most efficient point under any load condition. There have also been improvements in the main valve and hydraulic circuit to reduce hydraulic loss, resulting in higher efficiency and lower fuel consumption.

Large Displacement High Efficiency Pump

Large displacement hydraulic implement pumps provide high flow output at lower engine RPM as well as operation at the most efficient engine speed.



Working Mode Selection

The PC490LC-11 excavator is equipped with six working modes (P, E, L, B, ATT/P and ATT/E). Each mode is designed to match engine speed, pump flow, and system pressure to the application. The PC490LC-11 features an attachment mode (ATT/E) that allows operators to run attachments while in Economy mode.

Working Mode	Application	Advantage
P	Power mode	<ul style="list-style-type: none"> • Maximum production/power • Fast cycle times
E	Economy mode	<ul style="list-style-type: none"> • Good cycle times • Better fuel economy
L	Lifting mode	<ul style="list-style-type: none"> • Increases hydraulic pressure
B	Breaker mode	<ul style="list-style-type: none"> • Optimum engine rpm, hydraulic flow
ATT/P	Attachment Power mode	<ul style="list-style-type: none"> • Optimum engine rpm, hydraulic flow, 2-way • Power mode
ATT/E	Attachment Economy mode	<ul style="list-style-type: none"> • Optimum engine rpm, hydraulic flow, 2-way • Economy mode

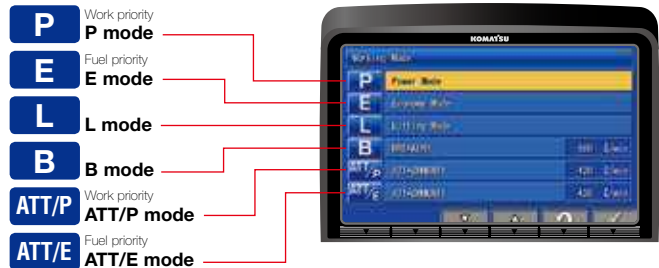

High Rigidity Work Equipment

Booms and arms are constructed with thick plates of high tensile strength steel. In addition, these structures are designed with large cross sectional areas and large one piece castings in the boom foot, the boom tip, and the arm tip. The result is work equipment that exhibits long term durability and high resistance to bending and torsional stress. A standard HD boom design provides increased strength and reliability.



WORKING ENVIRONMENT

PC490LC-11





Comfortable Working Space

Wide spacious cab

The wide spacious cab includes a heated air suspension seat with reclining backrest. The seat height and position are easily adjusted using a pull-up lever. The armrest position is easily adjusted together with the console. Reclining the seat further enables it to be fully laid back with the headrest attached.

Arm rest with simple height adjustment function

A knob and plunger on the armrests allows easy height adjustment without the use of tools.



Low vibration with cab damper mounting

Automatic climate control

Pressurised cab

Auxiliary input jack

Connecting a regular audio device to the auxiliary jack allows the operator to hear the sound from the stereo speakers installed in the cab.



Standard Equipment

Sliding window glass (left side)



AM/FM stereo radio



Remote intermittent wiper with windshield washer



Emergency stop & level indicator



ISO Level 2 OPG



Magazine box & cup holder



Defroster (conforms to the ISO standard)



One-touch storable front window lower glass



WORKING ENVIRONMENT

PC490LC-11

LARGE HIGH RESOLUTION LCD MONITOR



New Monitor Panel Interface Design

An updated large high resolution LCD colour monitor enables accurate and smooth work. The interface has been redesigned to display key machine information in a new user friendly interface. A rear view camera and an DEF level gauge display have been added to the default main screen. The interface has a function that enables the main screen mode to be switched, thus enabling the optimum screen information for the particular work situation to be displayed.

Indicators

- | | |
|------------------------------------|-----------------------------|
| 1 Auto-decelerator | 8 Fuel gauge |
| 2 Working mode | 9 DEF level gauge |
| 3 Travel speed | 10 Service meter, clock |
| 4 Ecology gauge | 11 Fuel consumption gauge |
| 5 Camera display | 12 Guidance icon |
| 6 Engine coolant temperature gauge | 13 Function switches |
| 7 Hydraulic oil temperature gauge | 14 Camera direction display |
| | 15 DEF level caution lamp |

Basic operation switches

- | | |
|-------------------------|-------------------------|
| 1 Auto-decelerator | 4 Buzzer cancel |
| 2 Working mode selector | 5 Wiper |
| 3 Travel speed selector | 6 Window washer |
| | 7 Auto climate controls |

Switchable Display Modes

The main screen display mode can be changed by pressing the F3 key.

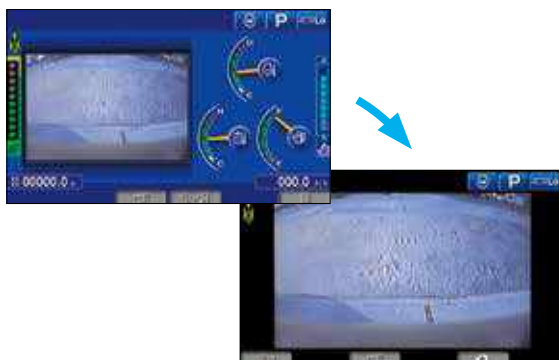

Visual user menu

Pressing the F6 key on the main screen displays the user menu screen. The menus are grouped for each function, and use easy-to-understand icons which enable the machine to be operated easily.



- | | |
|---------------------------------------|--------------------|
| 1 Energy saving guidance | 2 Machine settings |
| 3 Aftertreatment devices regeneration | 4 SCR information |
| 5 Maintenance | 6 Monitor setting |
| | 7 Message check |

Support Efficiency Improvement

Ecology guidance

While the machine is operating, ecology guidance pops up on the monitor screen to notify the operator of the status of the machine in real time.

Ecology gauge & fuel consumption gauge

The monitor screen is provided with an ecology gauge and also a fuel consumption gauge which is displayed continuously. In addition, the operator can set any desired target value of fuel consumption (within the range of the green display), enabling the machine to be operated with better fuel economy.



Ecology gauge Fuel consumption gauge
Ecology guidance

Operator Identification Function

An operator identification ID can be set up for each operator, and used to manage operation information of individual machines using KOMTRAX data. Data sent from KOMTRAX can be used to analyse operation status by operator as well as by machine.



Operation record, fuel consumption history, and ecology guidance record

The ecology guidance menu enables the operator to check the operation record, fuel consumption history and ecology guidance record from the ecology guidance menu, using a single touch, thus enabling the total fuel consumption to be reduced.

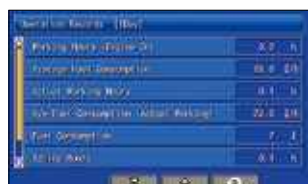

Operation record



Fuel consumption history



Ecology guidance record



MAINTENANCE FEATURES

Centralised engine check points

Locations of the engine oil check and filters are integrated into one side to allow easy maintenance and service.



Battery isolation switch

A standard battery isolation switch allows a technician to disconnect the power supply and lock out before servicing the machine.



Easy cleaning of cooling unit

Reverse-rotation function of the hydraulic driven fan facilitates cleaning of the cooling unit.

Fuel pre-filter with water separator

High efficiency fuel filter

Easy access to engine oil filter, engine oil, Ecology drain valve, fuel drain valve and water separator drain valve

Cab air filter

Washable cab floor mat

Sloping track frame



Long-life oils, filters

High performance filters are used in the hydraulic circuit and engine. By increasing the oil and filter replacement intervals, maintenance costs can be significantly reduced.

Engine oil & Engine oil filter	every 500 hours
Hydraulic oil	every 5000 hours
Hydraulic oil filter	every 1000 hours



Hydraulic oil filter (Ecology-white element)

Large capacity air cleaner

Large capacity air cleaner is comparable to that of larger machines. The larger air cleaner can extend air cleaner life during long-term operation and helps prevent early clogging, and resulting power loss. A radial seal design is used for reliability.



Diesel Exhaust Fluid (DEF) tank

A large tank volume extends operating time before refilling and is installed on the right front stairway for ease of access.



Maintenance Information

“Maintenance time caution lamp” display

When the remaining time to maintenance becomes less than 30 hours*, a maintenance time monitor appears. Pressing the F6 key switches the monitor to the maintenance screen.

* : The setting can be changed within the range between 10 and 200 hours.



Maintenance screen

Manual Stationary Regeneration

Under most conditions, active regeneration will occur automatically with no effect on machine operation. In case the operator needs to disable active regeneration or initiate a manual stationary regeneration, this can be easily accomplished through the monitor panel. A soot level indicator is displayed to show how much soot is trapped in the KDPF.



Soot level indicator

Aftertreatment device regeneration screen

Supports the DEF level and refill timing

The DEF level gauge is displayed continuously on the right side of the monitor screen. In addition, when DEF level is low, DEF low level guidance messages appear in pop up displays to inform the operator in real time.



DEF level gauge

DEF low level guidance

DT-type connectors

Sealed DT-type electrical connectors provide high reliability, water and dust resistance.

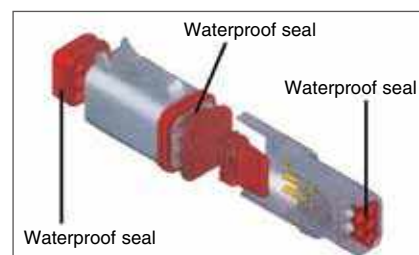

GENERAL FEATURES

ROPS CAB STRUCTURE

ROPS Cab (ISO 12117-2)

The machine is equipped with a ROPS cab that conforms to ISO 12117-2 for excavators as standard equipment. It also satisfies the requirements for Level 1 Operator Protective Guard (OPG) and top guard (ISO 10262).



Rear View Monitoring System

A new rear view monitoring system display has a rear view camera image that is continuously displayed together with the gauges and important vehicle information. This enables the operator to carry out work while easily checking the surrounding area.

Rear view camera



Rear view image on monitor



Low Vibration with Viscous Cab Mounts

The PC490LC-11 uses viscous mounts for the cab that incorporate a longer stroke and the addition of a spring. The cab damper mounting combined with a high rigidity deck reduces vibration at the operator's seat.

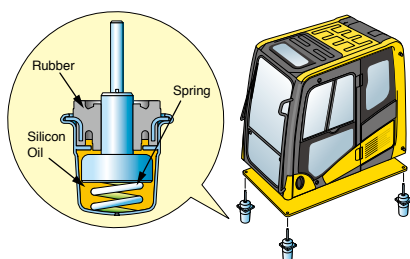

GENERAL FEATURES

Secondary engine shut down switch at base of seat to shutdown the engine.



Left and right side handrails



Seat belt caution indicator



Lock lever

Seat belt retractable

Tempered & tinted glass

Large mirrors

Slip-resistant plates

Thermal and fan guards

Pump/engine room partition

Travel alarm

Large cab entrance step



KALSS AUSTRALIAN STANDARD SPECIFICATION



Rotating Amber Beacon

Fitted with factory guard.



Level Indicator, Overload Alarm & Anti-Burst Valves

Enable safety and compliance when lifting suspended loads.



Additional Lighting

Extra lighting on cab and counterweight for improved visibility.



Proportional Hand Controls

Enables proportional hand control of attachment speed.



Higher Capacity Air Conditioner

With increased cool down performance.

Rock Guard

Reinforced steel plate and ribs to provide additional protection of arm structure.

Bump Rails

For upper protection when slewing.

Factory Fitted Quick Hitch and Hammer Piping

Enables use with a greater variety of attachments. Also fitted with provision for tilt circuit including valve.

Full Length Track Roller Guards

Protects track roller against rock and debris damage.

Heavy Duty Revolving Frame Under Covers

Protects and prevents ingress of material into engine bay.



Lower Front Window Guard

Protects cabin windscreen against rocks and debris.



Battery Isolation

Single pole, lockable Bosch-type battery isolation.



E-Stops

Allow compliance to site safety requirements.



Bolt-on Top Guard

OPG level 2 (ISO 10262) for falling object protection.

Specification also includes factory fitted provisions for fire extinguisher, turbo timer, UHF and vandal covers to reduce lead times and costs. Photos may include optional equipment.

SPECIFICATIONS



ENGINE

Model Komatsu SAA6D125E-7*
 Type Water-cooled, 4-cycle, direct injection
 Aspiration Variable geometry turbocharged, aftercooled, cooled EGR
 Number of cylinders 6
 Bore **125 mm** 4.92"
 Stroke **150 mm** 5.91"
 Piston displacement **11.04 ltr** 674 in³
 Horsepower:
 SAE J1995 Gross **270 kW** 362 HP
 ISO 9249 / SAE J1349 Net **268 kW** 359 HP
 Rated rpm 1900
 Governor All-speed control, electronic
 Fan drive method for radiator cooling Hydraulic
 *EPA Tier 4 Final emissions certified



HYDRAULICS

Type HydraMind (Hydraulic Mechanical Intelligence) system, closed-centre system with load sensing valve and pressure compensated valves, 6 selectable working modes

Main pump:

Pumps for Boom, arm, bucket, swing, and travel circuits
 Type Variable displacement axial piston type
 Maximum flow **780 ltr/min** 206 gal/min

Hydraulic motors:

Travel 2 x axial piston motor with parking brake
 Swing 1 x axial piston motor with swing holding brake

Relief valve setting:

Implement circuits **37.3 MPa 380 kgf/cm²** 5,400 psi
 Travel circuit **37.3 MPa 380 kgf/cm²** 5,400 psi
 Swing circuit **27.9 MPa 285 kgf/cm²** 4,050 psi
 Pilot circuit **3.2 MPa 33 kgf/cm²** 470 psi

Hydraulic cylinders:

(Number of cylinders – bore x stroke x rod diameter)

Boom **2-160 mm x 1570 mm x 110 mm** 6.3" x 61.8" x 4.3"
 Arm **1-185 mm x 1820 mm x 120 mm** 7.3" x 71.7" x 4.7"
 Bucket **1-160 mm x 1270 mm x 110 mm** 6.3" x 50" x 4.3"



DRIVES AND BRAKES

Steering control Two lever with pedals
 Drive method Hydrostatic
 Maximum drawbar pull **329 kN 33510 kgf** 73,880 lbf
 Gradeability 70%, 35°
 Maximum travel speed (auto shift):

High **5.5 km/h** 3.4 mph
 Mid **4.2 km/h** 2.6 mph
 Low **3.0 km/h** 1.9 mph

Service brake Hydraulic lock
 Parking brake Mechanical disc



SWING SYSTEM

Driven by Hydraulic motor
 Swing reduction Planetary gear
 Swing circle lubrication Grease-bathed
 Service brake Hydraulic lock
 Holding brake/Swing lock Mechanical disc brake
 Swing speed 9.0 rpm
 Swing torque **13414 kg•m** 97,024 ft lbs



UNDERCARRIAGE

Centre frame X-frame
 Track frame Box-section
 Track type Sealed
 Track adjuster Hydraulic
 Number of shoes (each side) 49
 Number of carrier rollers (each side) 2
 Number of track rollers (each side) 8



COOLANT & LUBRICANT CAPACITY (REFILLING)

Fuel tank **650 ltr** 172 U.S. gal
 Radiator **47.0 ltr** 12.4 U.S. gal
 Engine **38 ltr** 10.0 U.S. gal
 Final drive, each side **11.0 ltr** 2.9 U.S. gal
 Swing drive **20.0 ltr** 5.3 U.S. gal
 Hydraulic tank **248 ltr** 65.5 U.S. gal
 Diesel Exhaust Fluid (DEF) tank **39 ltr** 10.3 U.S. gal



OPERATING WEIGHT (APPROXIMATE)

Operating weight includes **7000 mm** one-piece HD boom, **3400 mm** arm, rated capacity of lubricants, coolant, full fuel tank, operator, standard equipment, KGA dual lock quick hitch, and SAE heaped **2.5 m³** bucket.

Triple-Grouser Shoes	Operating Weight	Ground Pressure
600 mm	48,690 kg	0.86 kg/cm ²
700 mm	49,190 kg	0.65 kg/cm ²
800 mm	49,680 kg	0.58 kg/cm ²

Component Weights

Arm including bucket cylinder and linkage
3400 mm 11'1" arm assembly **2141 kg** 4,720 lb
 One piece HD boom including arm cylinder
7000 mm 23'2" boom assembly **4017 kg** 8,856 lb
 Boom cylinders x 2 **366 kg** 807 lb
 Counterweight (standard) **9220 kg** 20,327 lb



DIMENSIONS

	Arm Length	3400 mm
A	Overall length	11930 mm
B	Length on ground (transport)	6705 mm
C	Overall height (to top of boom)*	3635 mm
D	Overall width	3565 mm
E	Overall height (to top of cab)*	3360 mm
F	Overall height (to top of handrail)*	3450 mm
G	Ground clearance, counterweight	1385 mm
H	Ground clearance, minimum	568 mm
I	Tail swing radius	3645 mm
J	Track length on ground	4350 mm
K	Track length	5385 mm
L	Track gauge	2740 mm
M	Width of crawler	3340 mm
N	Shoe width	600 mm
O	Grouser height	37 mm
P	Machine height to top of engine cover	3630 mm
Q	Machine upper width **	3360 mm
R	Distance, swing centre to rear end	3605 mm

* : Including grouser height ** : Including handrail

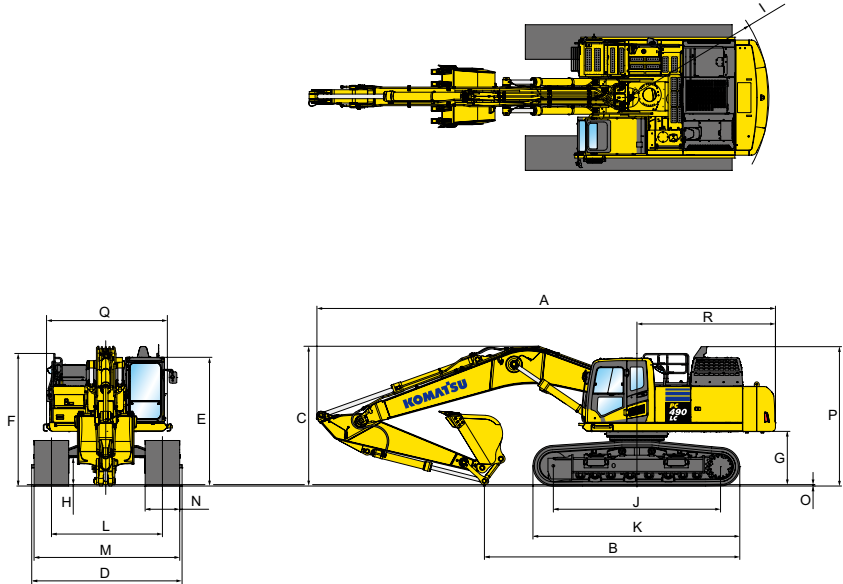

WORKING RANGE

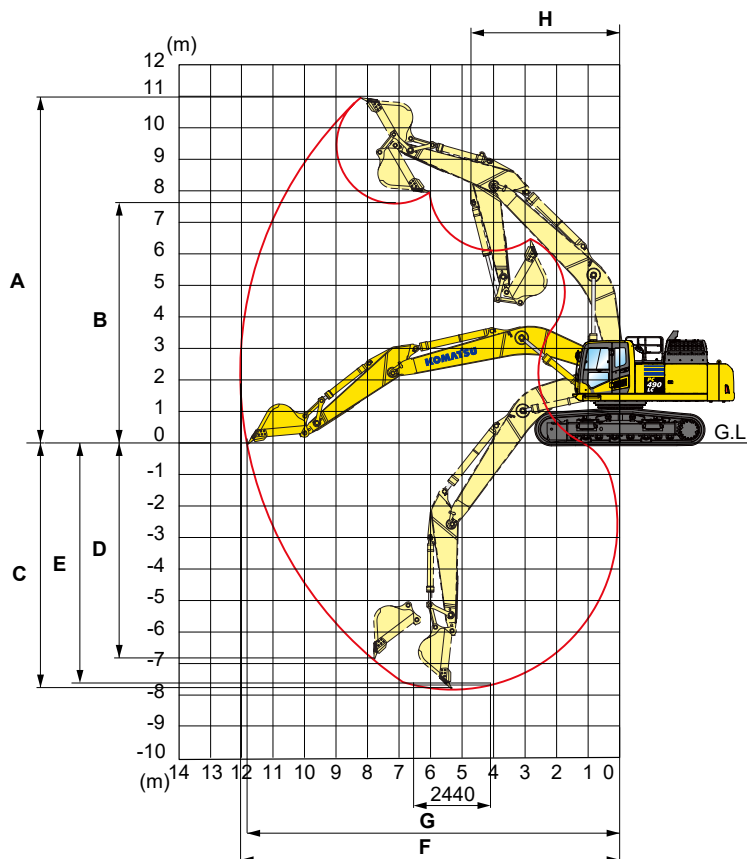

	Arm Length	3400 mm
A	Max. digging height	10980 mm
B	Max. dumping height	7630 mm
C	Max. digging depth	7755 mm
D	Max. vertical wall digging depth	6805 mm
E	Max. digging depth for 8' level bottom	7615 mm
F	Max. digging reach	12030 mm
G	Max. digging reach at ground level	11810 mm
H	Min. swing radius	4735 mm
SAE rating	Bucket digging force at power max.	239 kN 24,400 kg
	Arm crowd force at power max.	205 kN 20900 kg
ISO rating	Bucket digging force at power max.	275 kN 28000 kg
	Arm crowd force at power max.	214 kN 21800 kg

LIFT CAPACITIES



LIFTING CAPACITY WITH LIFTING MODE

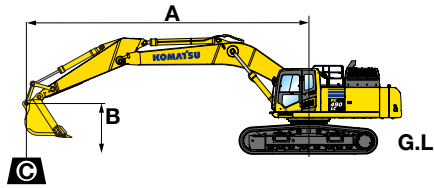

- A: Reach from swing centre
- B: Bucket hook height
- C: Lifting capacity
- Cf: Rating over front
- Cs: Rating over side
- ⊗: Rating at maximum reach

- Conditions:
- Boom length: 7000 mm
 - Arm length: 3400 mm
 - Shoes: 600 mm triple grouser
 - Bucket: 1914 kg

Unit: kg

B	A		3.0 m		4.5 m		6.0 m		7.5 m		9.0 m		⊗ MAX	
	Cf	Cs	Cf	Cs	Cf	Cs	Cf	Cs	Cf	Cs	Cf	Cs	Cf	Cs
7.5 m													*6350	*6350
6.0 m									*9700	*9700	*8950	7000	*6400	6000
4.5 m					*12590	*12590	*10700	9400	*9350	6800	*6600	5400		
3.0 m			*21250	20000	*15200	12750	*11900	8950	*9950	6550	*7050	5050		
1.5 m			*16000	*16000	*16850	12100	*12900	8550	*10500	6350	*7750	4950		
0.0 m			*16450	*16450	*17500	11650	*13400	8250	10550	6150	8700	5050		
-1.5 m	*9950	*9950	*22300	18250	*17250	11450	*13300	8100	10450	6050	9350	5400		
-3.0 m	*20250	*20250	*21050	18450	*16150	11500	*12450	8100	*9450	6100	*9450	6150		
-4.5 m	*22450	*22450	*17750	*17750	*13800	11700	*10350	8250			*9250	7700		
-6.0 m			*12500	*12500	*9300	*9300					*8150	*8150		

*Load is limited by hydraulic capacity rather than tipping. Ratings are based on SAE standard No. J1097. Rated loads do not exceed 87% of hydraulic lift capacity or 75% of tipping load.



PC490LC-11



STANDARD EQUIPMENT

- 3 speed travel with auto shift
- Alternator, 90 Ampere, 24 V
- AM/FM radio
- Arm, 3400 mm
- Automatic air conditioner, large capacity
- Automatic engine warm-up system
- Auto idle
- Auto idle shut down
- Auxiliary input (3.5 mm jack)
- Batteries, large capacity (2 x 12 V)
- Battery isolation switch, lockable
- Boom, 7000 mm
- Boom and arm burst valve protection
- Bump rails
- Cab guards
 - Lower front window guard
 - Integrated top guard, OPG Level 1
 - Bolt on top guard, OPG Level 2
- Carrier rollers, (2 each side)
- Converter, (2) x 12 V
- Counterweight, 9220 kg
- Dry type air cleaner, double element
- Dual flow hammer piping
- Electric horn
- Emergency stops (3)
- Engine, Komatsu SAA6D125E-7
- EMMS monitoring system
- Fan guard structure
- Engine overheat prevention system
- Fuel system pre-filter 10 micron
- Grease sealed track chain
- High back air suspension seat, with heat
- High pressure in-line hydraulic filters
- Hydraurmind closed centre load sensing system
- Hydraulic cooling fan (reversible)
- Hydraulic track adjusters
- KOMTRAX Level 5.0
- Large LCD colour monitor, high resolution
- Level indicator
- Lock lever
- Lock lever, auto lock
- Mirrors (LH, RH & sidewise)
- Operator identification system
- Overload alarm
- Power maximising system
- PPC hydraulic control system
- Proportional control handles
- Provision for tilt circuit, including valve
- Pump/engine room partition cover
- Radiator and oil cooler dustproof net
- Rear reflectors
- Rearview monitoring system (1 camera)
- Revolving frame undercovers, heavy duty
- ROPS cab (ISO 12117-2) with vandal guard provisions
- Rotating beacon with guard
- Seat belt indicator
- Seat belt, retractable, 78 mm
- Secondary engine shutdown switch
- Side by side coolers
- Slip resistant foot plates
- Starter motor, 11.0 kW / 24 V x 1
- Suction fan
- Thermal and fan guards
- Track frame swivel guard
- Track roller guards, full length
- Track rollers, 8 each side
- Track shoes, triple grouser, 600 mm
- Travel alarm
- Two boom mode settings
- Quick hitch piping with safety switch and alarm
- Working lights
 - 1 x boom
 - 1 x RH
 - 3 x cab
 - 1 x counterweight
- Working mode selection system



OPTIONAL EQUIPMENT

- Autogrease system
- Battery isolation switch, dual pole, lockable
- Cab guard
 - Full front guard, OPG Level 2
- Canvas seat cover
- Fire extinguisher, 1.5 kg
- Fire extinguisher, 4.5 kg
- Fire extinguisher, 9 kg
- Fuel cap vandal guard
- Jump start receptacle
- Komvision
- Radio, multimedia system
- Radio, UHF
- Starter circuit isolation, lockable
- Track shoes, triple grouser, 700 mm
- Track shoes, triple grouser, 800 mm
- Turbo timer
- Window tinting



ATTACHMENT OPTIONS

- Bucket, general purpose, KGA 1200 mm, 1.45 m³
- Bucket, general purpose, KGA 1500 mm, 1.86 m³
- Bucket, general purpose, KGA 1700 mm, 2.15 m³
- Bucket, slope finishing, KGA 2500 mm, 3.29 m³
- Bucket, general purpose, factory, 2.1 m³
- Bucket, general purpose, 2.5 m³
- Bucket, general purpose, direct pin, 2.7 m³
- Quick hitch, KGA, dual lock
- Ripper, KGA, single tyne

For a complete list of available attachments, please contact your local Komatsu representative.

